

Series IS12, size 2



AVENTICS™ Series IS12, size 2



































5/2-directional valve, Series IS12, size 2

- ISO 5599-1
- ISO 2
- 5/2
- With air spring return With spring return With differential piston
- single solenoid double solenoid
- $Q_n = 2500$ l/min
- Compressed air connection output Base plate ISO 5599-1
- Electrical connection Plug, M12, 3-pin
- Manual override without detent with detent



Type	Spool valve, positive overlapping
Sealing principle	Soft sealing
Blocking principle	Single base plate principle
Connection type	Plate connection
Standards	ISO 5599-1, ISO 2
Working pressure min./max.	See table below
Control pressure min./max.	See table below
Ambient temperature min./max.	0 ... 50 °C
Medium temperature min./max.	0 ... 50 °C
Medium	Compressed air
Max. particle size	5 µm
Oil content of compressed air	0 ... 5 mg/m ³
Nominal flow Q_n	2500 l/min
Protection class with connection	IP65
LED status display	Yellow
Nominal resistance	1480 Ω
Duty cycle	100 %
Typ. switch-on time	See table below
Typ. switch-off time	See table below
Mounting screw	M6 with hexagon socket
Mounting screw tightening torque	4 Nm
Weight	See table below

Technical data

Part No.		MO	Operational voltage DC	Voltage tolerance DC
0820025250			24 V	-10% / +10%
0820025251			24 V	-10% / +10%
0820025300			24 V	-10% / +10%
0820025301			24 V	-10% / +10%
0820025325			24 V	-10% / +10%
0820025326			24 V	-10% / +10%
0820025329			24 V	-10% / +10%
0820025330			24 V	-10% / +10%
0820025252			24 V	-10% / +10%
0820025253			24 V	-10% / +10%
0820025302			24 V	-10% / +10%
0820025303			24 V	-10% / +10%
0820025327			24 V	-10% / +10%
0820025328			24 V	-10% / +10%
0820025331			24 V	-10% / +10%
0820025332			24 V	-10% / +10%

Part No.	Power consumption DC	Pilot	Working pressure min./max.
0820025250	0,35 W	Internal	2 ... 10 bar
0820025251	0,35 W	External	-0,9 ... 10 bar
0820025300	0,35 W	Internal	2,8 ... 10 bar
0820025301	0,35 W	External	-0,9 ... 10 bar
0820025325	0,35 W	Internal	2 ... 10 bar
0820025326	0,35 W	External	-0,9 ... 10 bar
0820025329	0,35 W	Internal	2 ... 10 bar
0820025330	0,35 W	External	-0,9 ... 10 bar
0820025252	0,35 W	Internal	2 ... 10 bar
0820025253	0,35 W	External	-0,9 ... 10 bar
0820025302	0,35 W	Internal	2,8 ... 10 bar
0820025303	0,35 W	External	-0,9 ... 10 bar
0820025327	0,35 W	Internal	2 ... 10 bar
0820025328	0,35 W	External	-0,9 ... 10 bar
0820025331	0,35 W	Internal	2 ... 10 bar
0820025332	0,35 W	External	-0,9 ... 10 bar

Part No.	Control pressure min./max.	Typ. switch-on time	Typ. switch-off time
0820025250	2 ... 10 bar	24 ms	40 ms
0820025251	2 ... 10 bar	24 ms	40 ms
0820025300	2,2 ... 10 bar	20 ms	45 ms
0820025301	2,2 ... 10 bar	20 ms	56 ms
0820025325	1 ... 10 bar	18 ms	18 ms
0820025326	1 ... 10 bar	18 ms	18 ms

Part No.	Control pressure min./max.	Typ. switch-on time	Typ. switch-off time
0820025329	1 ... 10 bar	-	-
0820025330	1 ... 10 bar	-	-
0820025252	2 ... 10 bar	24 ms	40 ms
0820025253	2 ... 10 bar	24 ms	40 ms
0820025302	2,2 ... 10 bar	20 ms	45 ms
0820025303	2,2 ... 10 bar	20 ms	56 ms
0820025327	1 ... 10 bar	18 ms	18 ms
0820025328	1 ... 10 bar	18 ms	18 ms
0820025331	1 ... 10 bar	-	-
0820025332	1 ... 10 bar	-	-

Part No.	Electrical connection Pilot valve	Weight
0820025250	Plug M12 3-pin	0,53 kg
0820025251	Plug M12 3-pin	0,53 kg
0820025300	Plug M12 3-pin	0,51 kg
0820025301	Plug M12 3-pin	0,51 kg
0820025325	Plug M12 3-pin	0,51 kg
0820025326	Plug M12 3-pin	0,51 kg
0820025329	Plug M12 3-pin	0,54 kg
0820025330	Plug M12 3-pin	0,54 kg
0820025252	Plug M12 3-pin	0,53 kg
0820025253	Plug M12 3-pin	0,53 kg
0820025302	Plug M12 3-pin	0,51 kg
0820025303	Plug M12 3-pin	0,51 kg
0820025327	Plug M12 3-pin	0,51 kg
0820025328	Plug M12 3-pin	0,51 kg
0820025331	Plug M12 3-pin	0,54 kg
0820025332	Plug M12 3-pin	0,54 kg

Nominal flow Q_n at 6 bar and $\Delta p = 1$ bar, MO = Manual override

Technical information

The min. control pressure must be adhered to, since otherwise faulty switching and valve failure may result!

The pressure dew point must be at least 15 °C under ambient and medium temperature and may not exceed 3 °C .

The oil content of compressed air must remain constant during the life cycle.

Use only the approved oils from AVENTICS. Further information can be found in the "Technical information" document (available in the MediaCentre).

Switch-on power: 1 W for 40 ms

Technical information

Housing	Polyamide
Seals	Acrylonitrile butadiene rubber
Front plate	Polyamide

Dimensions

Dimensions

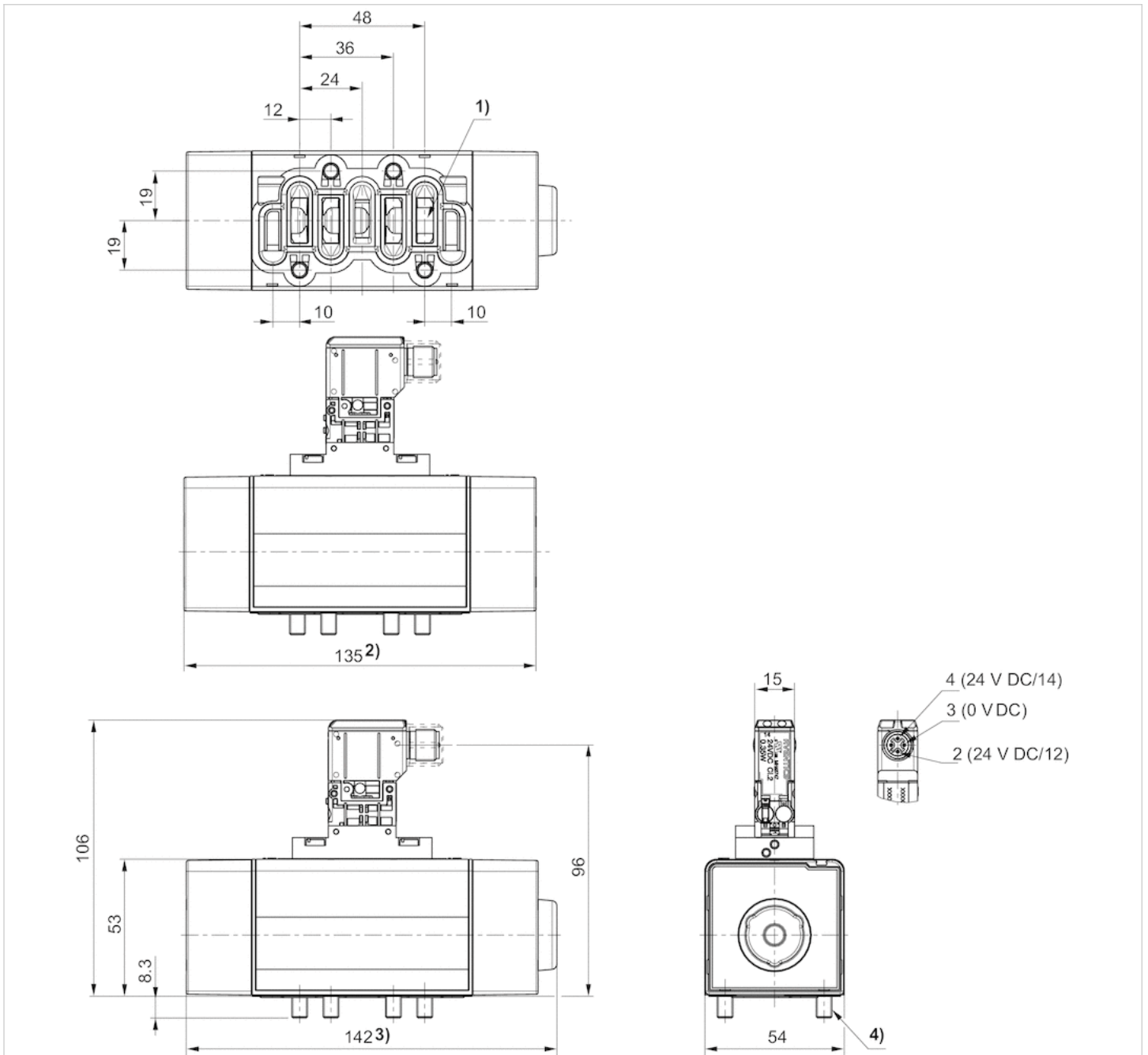

- 1) according to ISO 5599-1
- 2) with air return
- 3) With spring return
- 4) 4 screws M4x40 DIN 912

























5/3-directional valve, Series IS12, size 2

- ISO 5599-1
- ISO 2
- 5/3
- double solenoid
- closed center exhausted center pressurized center
- $Q_n = 1700-2400$ l/min
- Compressed air connection output Base plate ISO 5599-1
- Electrical connection Plug, M12, 3-pin
- Manual override without detent with detent



Type	Spool valve, positive overlapping
Sealing principle	Soft sealing
Blocking principle	Single base plate principle
Connection type	Plate connection
Standards	ISO 5599-1, ISO 2
Working pressure min./max.	See table below
Control pressure min./max.	3 ... 10 bar
Ambient temperature min./max.	0 ... 50 °C
Medium temperature min./max.	0 ... 50 °C
Medium	Compressed air
Max. particle size	5 µm
Oil content of compressed air	0 ... 5 mg/m ³
Nominal flow Q_n	See table below
Protection class with connection	IP65
LED status display	Yellow
Nominal resistance	1480 Ω
Duty cycle	100 %
Typ. switch-on time	See table below
Typ. switch-off time	See table below
Mounting screw	M6 with hexagon socket
Mounting screw tightening torque	4 Nm
Weight	0,57 kg

Technical data

Part No.		MO		Operational voltage DC
0820028275			closed center	24 V
0820028276			closed center	24 V
0820028375			exhausted center	24 V
0820028376			exhausted center	24 V
0820028425			pressurized center	24 V
0820028426			pressurized center	24 V
0820028277			closed center	24 V
0820028278			closed center	24 V
0820028377			exhausted center	24 V
0820028378			exhausted center	24 V
0820028427			pressurized center	24 V
0820028428			pressurized center	24 V

Part No.	Voltage tolerance DC	Power consumption DC	Pilot	Nominal flow Qn
0820028275	-10% / +10%	0,35 W	Internal	2400 l/min
0820028276	-10% / +10%	0,35 W	External	2400 l/min
0820028375	-10% / +10%	0,35 W	Internal	1700 l/min
0820028376	-10% / +10%	0,35 W	External	1700 l/min
0820028425	-10% / +10%	0,35 W	Internal	1800 l/min
0820028426	-10% / +10%	0,35 W	External	1800 l/min
0820028277	-10% / +10%	0,35 W	Internal	2400 l/min
0820028278	-10% / +10%	0,35 W	External	2400 l/min
0820028377	-10% / +10%	0,35 W	Internal	1700 l/min
0820028378	-10% / +10%	0,35 W	External	1700 l/min
0820028427	-10% / +10%	0,35 W	Internal	1800 l/min
0820028428	-10% / +10%	0,35 W	External	1800 l/min

Part No.	Working pressure min./max.	Typ. switch-on time	Typ. switch-off time
0820028275	2,5 ... 10 bar	22 ms	-
0820028276	2,5... 10 bar	22 ms	-
0820028375	2,5 ... 10 bar	20 ms	45 ms
0820028376	2,5 ... 10 bar	20 ms	45 ms
0820028425	2,5 ... 10 bar	20 ms	-
0820028426	2,5 ... 10 bar	20 ms	-
0820028277	2,5 ... 10 bar	22 ms	-
0820028278	2,5 ... 10 bar	22 ms	-
0820028377	2,5 ... 10 bar	20 ms	45 ms
0820028378	2,5 ... 10 bar	20 ms	45 ms
0820028427	2,5 ... 10 bar	20 ms	-
0820028428	2,5 ... 10 bar	20 ms	-

Part No.	Electrical connection Pilot valve
0820028275	Plug M12 3-pin
0820028276	Plug M12 3-pin
0820028375	Plug M12 3-pin
0820028376	Plug M12 3-pin
0820028425	Plug M12 3-pin
0820028426	Plug M12 3-pin
0820028277	Plug M12 3-pin
0820028278	Plug M12 3-pin
0820028377	Plug M12 3-pin
0820028378	Plug M12 3-pin
0820028427	Plug M12 3-pin
0820028428	Plug M12 3-pin

Nominal flow Q_n at 6 bar and $\Delta p = 1$ bar, MO = Manual override

Technical information

The min. control pressure must be adhered to, since otherwise faulty switching and valve failure may result!

The pressure dew point must be at least 15 °C under ambient and medium temperature and may not exceed 3 °C .

The oil content of compressed air must remain constant during the life cycle.

Use only the approved oils from AVENTICS. Further information can be found in the "Technical information" document (available in the MediaCentre).

Switch-on power: 1 W for 40 ms

Technical information

Housing	Polyamide
Seals	Acrylonitrile butadiene rubber
Front plate	Polyamide

Dimensions

Dimensions

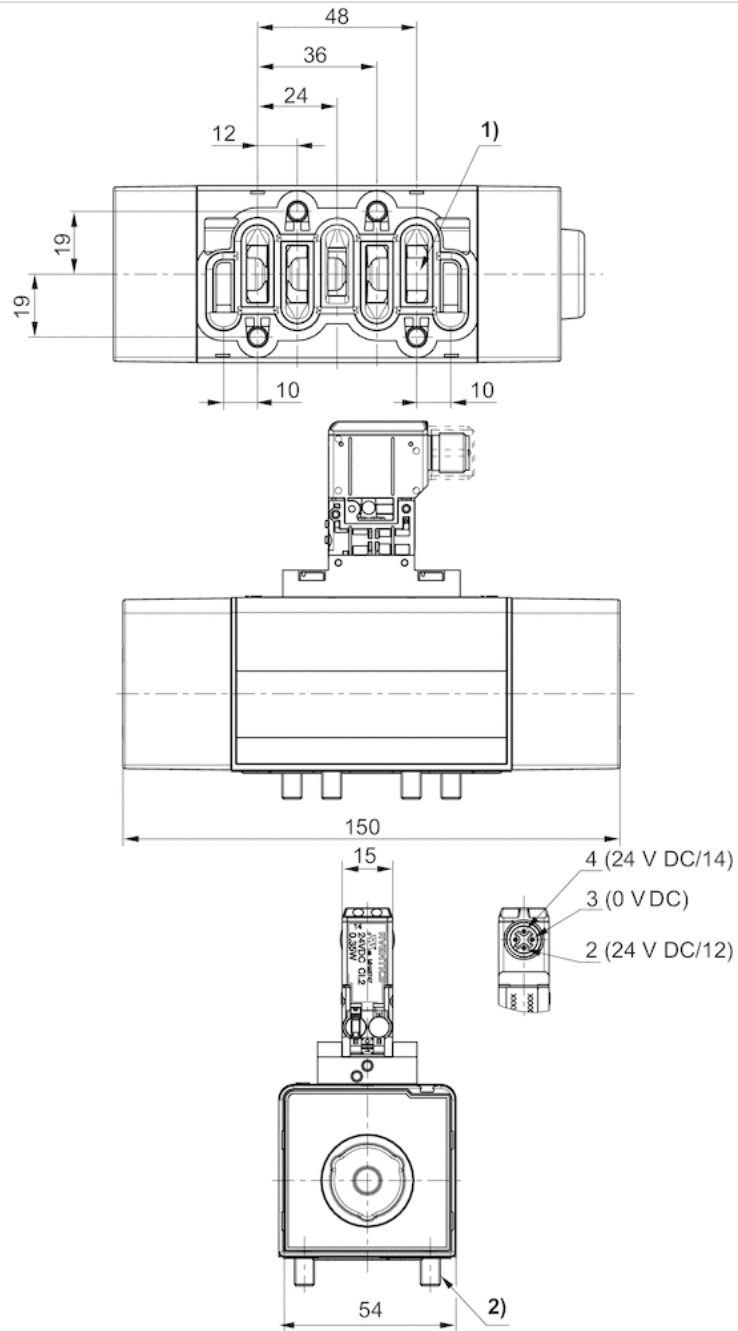

- 1) according to ISO 5599-1
- 2) 4 screws M4x40 DIN 912



















5/2-directional valve, Series IS12-PD, size 2

- ISO 5599-1
- ISO 2
- 5/2
- With differential piston
- single solenoid
- $Q_n = 2500$ l/min
- Compressed air connection output Base plate DIN ISO 5599 size 2
- Electrical connection Plug, EN 175301-803, form A Plug, M12
- Manual override without detent without



Type	Spool valve, positive overlapping
Sealing principle	Soft sealing
Blocking principle	Single base plate principle
Connection type	Plate connection
Standards	ISO 5599-1, ISO 2
Working pressure min./max.	See table below
Control pressure min./max.	3 ... 10 bar
Ambient temperature min./max.	0 ... 50 °C
Medium temperature min./max.	0 ... 50 °C
Medium	Compressed air
Max. particle size	5 µm
Oil content of compressed air	0 ... 0,01 mg/m ³
Nominal flow Q_n	2500 l/min
Protection class with connection	IP65
Compatibility index	15
Duty cycle	100 %
Switch-on time max.	20 ms
Switch-off time max.	50 ms
Type sensor	electronic PNP, with LED
Sensor connection	Plug, M8, 3-pin, with knurled screw
Operating voltage sensor DC min./max.	10 ... 30 V DC
Voltage drop sensor U at I_{max}	≤ 2,5 V
Vibration resistance sensor	10 - 55 Hz, 1 mm
Shock resistance sensor	30 g / 11 ms
Cable length sensor	0,3 m
Protection class sensor acc. to DIN EN 61140	Class III
Mounting screw	M6 with hexagon socket
Weight	See table below

Technical data

Part No.		MO	Operational voltage DC	Voltage tolerance DC
R422003650			-	-
R422003649			24 V	-10% / +10%
R422003655			24 V	-10% / +10%
R422003657			24 V	-10% / +10%
R422003653		-	-	-
R422003652			-	-
R422003651			24 V	-10% / +10%
R422003656			24 V	-10% / +10%
R422003658			24 V	-10% / +10%
R422003654		-	-	-

Part No.	Power consumption DC	Pilot	Working pressure min./max.	Compatibility index
R422003650	-	Internal	3 ... 10 bar	15
R422003649	4,4 W	Internal	3 ... 10 bar	15
R422003655	4,5 W	Internal	3 ... 10 bar	15
R422003657	4,4 W	Internal	3 ... 10 bar	15
R422003653	-	Internal	3 ... 10 bar	15
R422003652	-	External	-0,9 ... 10 bar	15
R422003651	4,4 W	External	-0,9 ... 10 bar	15
R422003656	4,5 W	External	-0,9 ... 10 bar	15
R422003658	4,4 W	External	-0,9 ... 10 bar	15
R422003654	-	External	-0,9 ... 10 bar	15

Part No.	Electrical connection Pilot valve	basic valve with electrical connector	Weight	Fig.
R422003650	-	Basic valve without coil	0,52 kg	Fig. 1
R422003649	Plug EN 175301-803, form A	-	0,61 kg	Fig. 1
R422003655	Plug M12	-	0,61 kg	Fig. 2
R422003657	Plug EN 175301-803, form A	-	0,61 kg	Fig. 1
R422003653	-	Basic valve without coil	0,52 kg	Fig. 1
R422003652	-	Basic valve without coil	0,52 kg	Fig. 1
R422003651	Plug EN 175301-803, form A	-	0,61 kg	Fig. 1
R422003656	Plug M12	-	0,61 kg	Fig. 2
R422003658	Plug EN 175301-803, form A	-	0,61 kg	Fig. 1
R422003654	-	Basic valve without coil	0,52 kg	Fig. 1

Part No.	
R422003650	-
R422003649	-
R422003655	-
R422003657	1)
R422003653	-

Part No.	
R422003652	-
R422003651	-
R422003656	-
R422003658	1)
R422003654	-

The UL certification only applies to the coil, not to the valve., Nominal flow Qn at 6 bar and Δp = 1 bar

1) With UL coil

Technical information

The min. control pressure must be adhered to, since otherwise faulty switching and valve failure may result!

The pressure dew point must be at least 15 °C under ambient and medium temperature and may not exceed 3 °C .

The oil content of compressed air must remain constant during the life cycle.

Use only the approved oils from AVENTICS. Further information can be found in the “Technical information” document (available in the MediaCentre).

When the valve is not actuated, the sensor sends a signal through pin 4 of the sensor connection.

When the valve is actuated, the sensor does not send a signal through pin 4 of the sensor connection.

The valve with position detection is possible to be used in categories 3 and 4 according to ISO 13849 in order to reach a Performance Level (PL) of the control system up to PL = e.

On its own, the valve with position detection is not a safety component and is not a complete safety solution. It is designed to increase the diagnostic coverage (DC) of the control system.

For use in categories 3 to 4, additional requirements of DIN EN ISO 13849-1:2008-12 (e.g. CCF, DC, PLr, software, systematic errors) are taken into consideration by the user.

Technical information

Housing	Polyamide Aluminum
Seals	Acrylonitrile butadiene rubber

Dimensions

Dimensions, Fig. 1

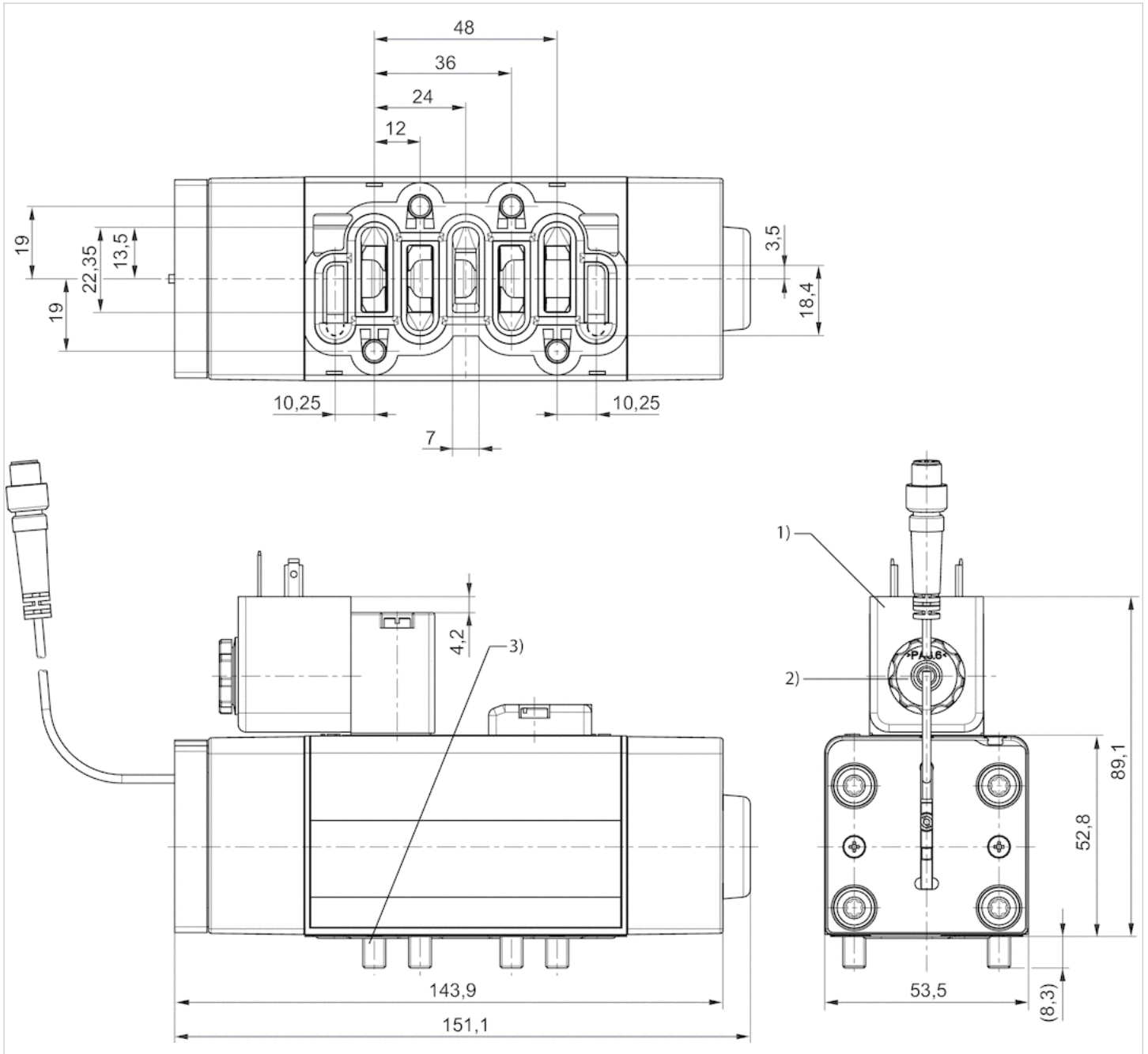

- 1) Adjustable coil 3x90°
- 2) Tightening torque for lock nut: 0.6 + 0.2 Nm
- 3) Tightening torque for mounting screws: 4,0 ± 0,5 Nm

Dimensions, Fig. 2

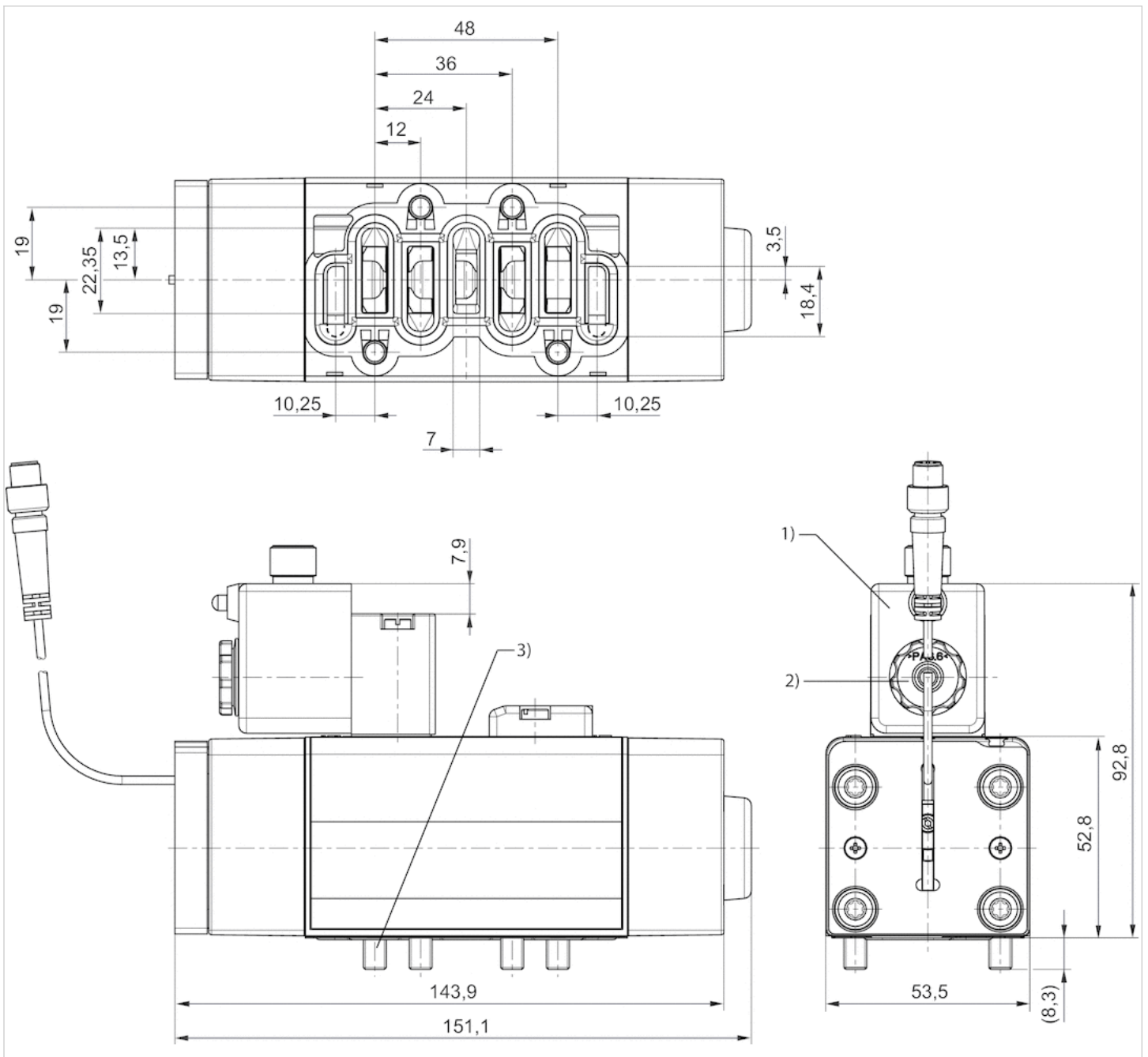

- 1) Adjustable coil 3x90°
- 2) Tightening torque for lock nut: 0.6 + 0.2 Nm
- 3) Tightening torque for mounting screws: 4,0 ± 0,5 Nm

3/2-directional valve, Dual valve, IS12-PD series, size 2

- ISO 13849-1
- Safe pressurization and exhaust $Q_n = 3000 \text{ l/min}$ (Exhaust)
- With spring return
- single solenoid
- Compressed air connection output G 1/2
- Electrical connection Plug, M12 Plug, EN 175301-803, form A
- Manual override with detent



Type	Spool valve
Sealing principle	Soft sealing
Blocking principle	Double base plate principle
Connection type	Plate connection
Standards	ISO 13849-1
Working pressure min./max.	See table below
Control pressure min./max.	3 ... 10 bar
Ambient temperature min./max.	0 ... 50 °C
Medium temperature min./max.	0 ... 50 °C
Medium	Compressed air
Max. particle size	5 µm
Oil content of compressed air	0 ... 0,01 mg/m ³
Protection class with connection	IP65
Compatibility index	15
Duty cycle	100 %
Typ. switch-on time	20 ms
Typ. switch-off time	50 ms
Type sensor	electronic PNP, with LED
Sensor connection	M8x1, 3-pin, with knurled screw
Operating voltage sensor DC min./max.	10 ... 30 V DC
Voltage drop sensor U at I _{max}	≤ 2,5 V
Vibration resistance sensor	10 - 55 Hz, 1,5 mm
Shock resistance sensor	30 g / 11 ms
Cable length sensor	0,3 m
Protection class sensor acc. to DIN EN 61140	Class III
Weight	3,7 kg

Technical data

Part No.		MO	Operational voltage DC	Voltage tolerance DC
R422003729			24 V	-10% / +10%
R422003730			24 V	-10% / +10%
R422003980			24 V	-10% / +10%
R422003982			24 V	-10% / +10%

Part No.	Power consumption DC	Pilot	Nominal flow 1 ► 2	Nominal flow 2 ► 3
R422003729	4,5 W	External	1950 l/min	3000 l/min
R422003730	4,5 W	Internal	1950 l/min	3000 l/min
R422003980	4,4 W	External	1950 l/min	3000 l/min
R422003982	4,4 W	Internal	1950 l/min	3000 l/min

Part No.	Working pressure min./max.	Compatibility index	Electrical connection Pilot valve
R422003729	1 ... 10 bar	15	Plug M12
R422003730	3 ... 10 bar	15	Plug M12
R422003980	1 ... 10 bar	15	Plug EN 175301-803, form A
R422003982	3 ... 10 bar	15	Plug EN 175301-803, form A

Nominal flow Q_n at 6 bar and Δp = 1 bar

Technical information

The min. control pressure must be adhered to, since otherwise faulty switching and valve failure may result!

The pressure dew point must be at least 15 °C under ambient and medium temperature and may not exceed 3 °C .

The oil content of compressed air must remain constant during the life cycle.

Use only the approved oils from AVENTICS. Further information can be found in the "Technical information" document (available in the MediaCentre).

When the valve is not actuated, the sensor sends a signal through pin 4 of the sensor connection.

When the valve is actuated, the sensor does not send a signal through pin 4 of the sensor connection.

The dual valve includes two IS12-PD-5/2-SR valves with position detection and fulfills the safety function "safe venting" and "protection against unexpected start-up". The dual valve permits use in categories 3 and 4 in accordance with ISO 13849-1 to achieve a control system performance level (PL) of up to PL = e.

On its own, the valve with position detection is not a safety component and is not a complete safety solution. It is designed to increase the diagnostic coverage (DC) of the control system.

For use in categories 3 to 4, additional requirements of DIN EN ISO 13849-1:2008-12 (e.g. CCF, DC, PLr, software, systematic errors) are taken into consideration by the user.

Technical information

Housing	Polyamide Aluminum
Seals	Acrylonitrile butadiene rubber

Dimensions

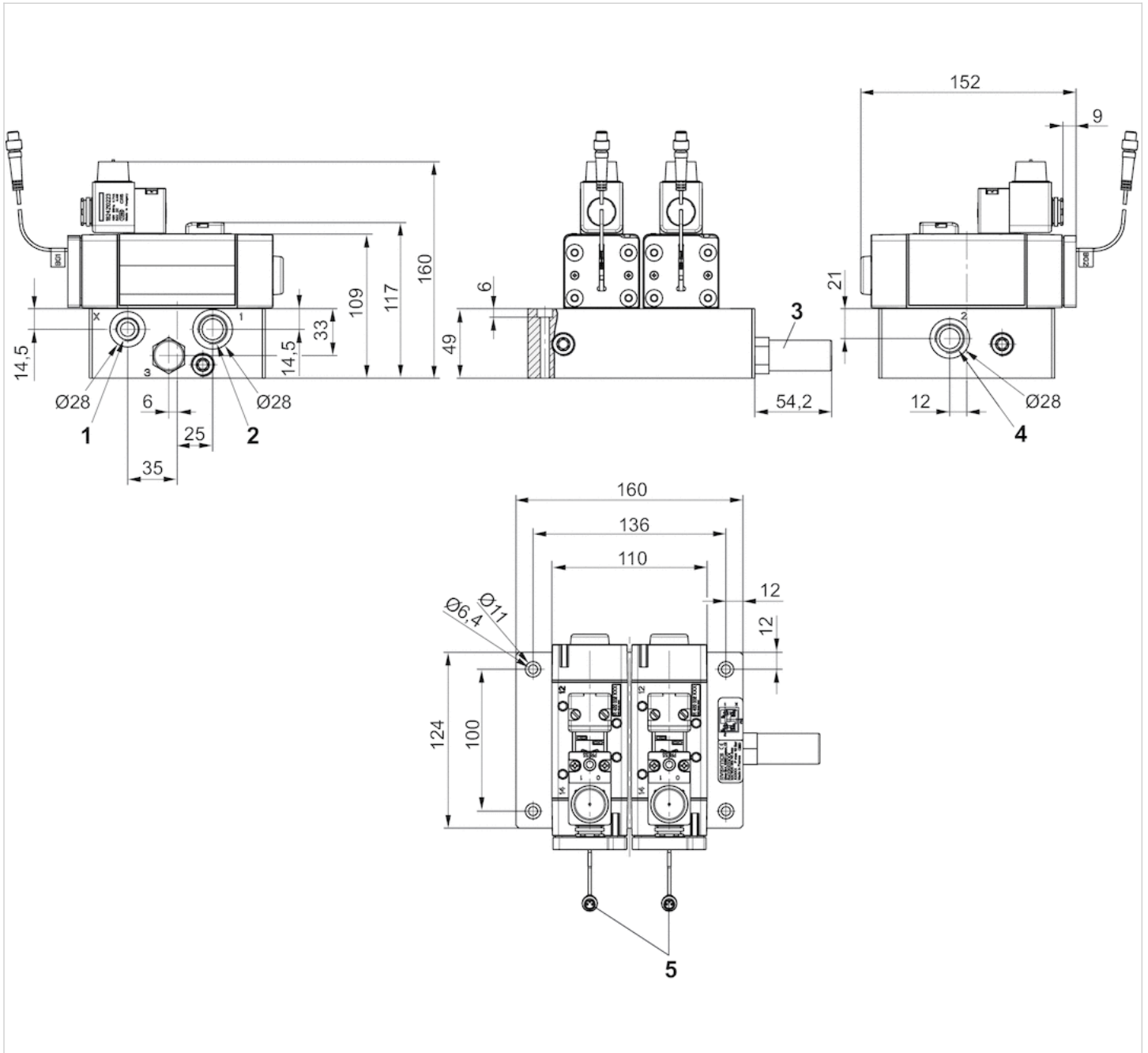

- 1) External pilot pressure G3/8
- 2) Input pressure G1/2
- 3) Exhaust G 1/2
- 4) Output pressure G1/2
- 5) Sensor plug M8, 3-pin



5/2-directional valve, Series IS12, size 2

- Single air pilot
- $Q_n = 2500$ l/min
- Plate connection
- Compressed air connection output Base plate ISO 5599-1



Type	Spool valve, positive overlapping
Pilot	External
Blocking principle	Single base plate principle
Sealing principle	Soft sealing
Connection type	Plate connection
Standards	ISO 5599-1, ISO 2
Nominal flow Q_n	2500 l/min
Compressed air connection version pneumatic port	Base plate ISO 5599-1
Working pressure min./max.	See table below
Control pressure min./max.	See table below
Ambient temperature min./max.	0 ... 80 °C
Medium temperature min./max.	0 ... 80 °C
Medium	Compressed air Class 5-4-4 class 6-4-3
Max. particle size	5 μm
Oil content of compressed air	0 ... 5 mg/m ³
Mounting screw	M6 with hexagon socket
Mounting screw tightening torque	4 Nm
Weight	See table below

Technical data

Part No.		version pneumatic port	Working pressure min./max.	Control pressure min./max.
0820225101		Base plate ISO 5599-1	2 ... 10 bar	2 ... 10 bar
0820225102		Base plate ISO 5599-1	-0,9 ... 10 bar	2,5 ... 10 bar

Part No.	Weight	
0820225101	0,48 kg	1)
0820225102	0,46 kg	-

Nominal flow Q_n at 6 bar and $\Delta p = 1$ bar

1) External control pressure: see diagram

Technical information

The min. control pressure must be adhered to, since otherwise faulty switching and valve failure may result!

The pressure dew point must be at least 15 °C under ambient and medium temperature and may not exceed 3 °C .

The oil content of compressed air must remain constant during the life cycle.

Use only the approved oils from AVENTICS. Further information can be found in the "Technical information" document (available in the MediaCentre).

Technical information

Housing	Polyamide
Seals	Acrylonitrile butadiene rubber
Front plate	Polyamide

Dimensions

Dimensions

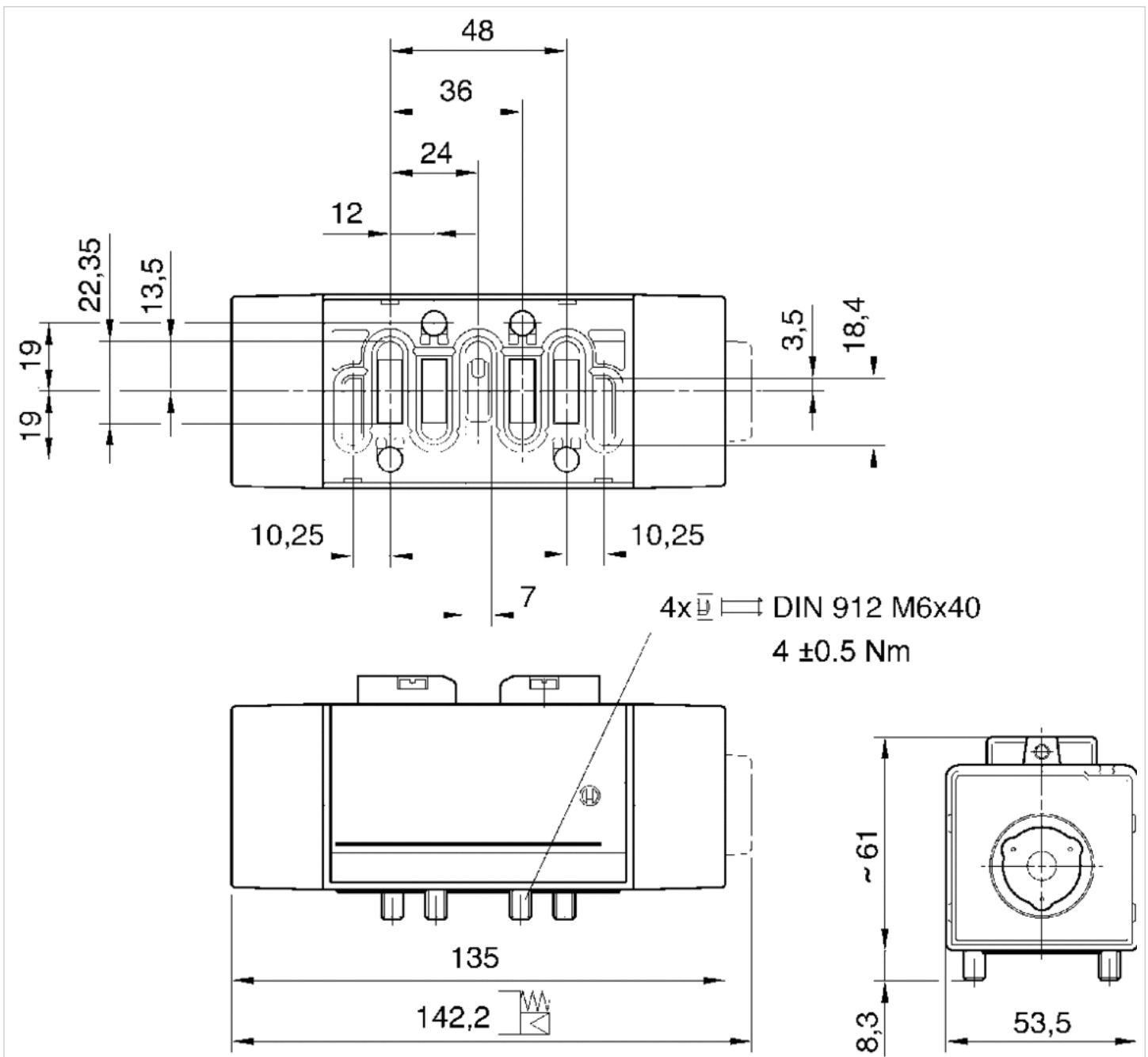

Diagrams

External pilot pressure

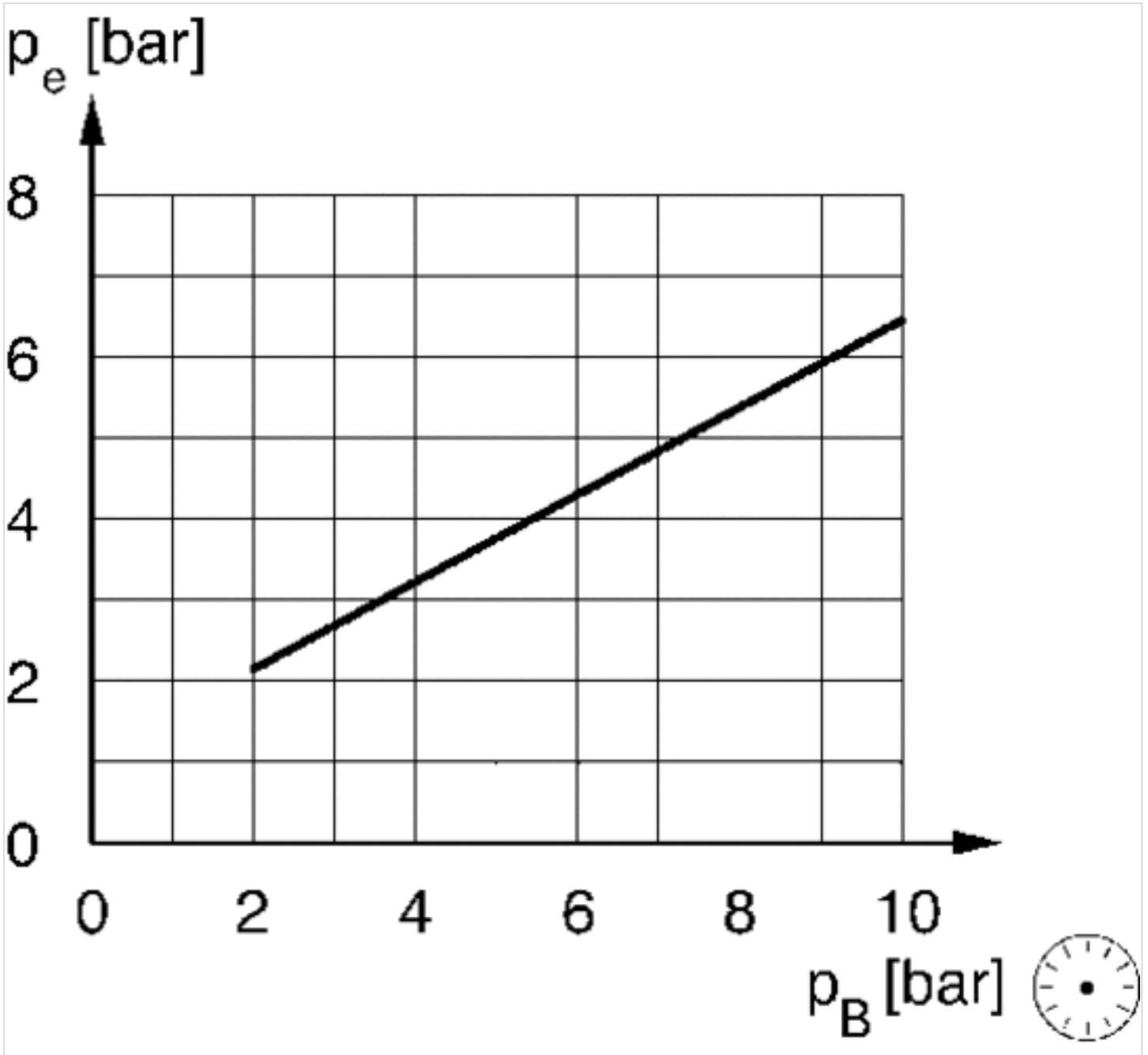

p_e = external control pressure, min.
 p_B = Working pressure



5/2-directional valve, Series IS12, size 2

- double air pilot
- $Q_n = 2500$ l/min
- Plate connection
- Compressed air connection output Base plate ISO 5599-1



Type	Spool valve, positive overlapping
Pilot	External
Blocking principle	Single base plate principle
Sealing principle	Soft sealing
Connection type	Plate connection
Standards	ISO 5599-1, ISO 2
Nominal flow Q_n	2500 l/min
Compressed air connection version pneumatic port	Base plate ISO 5599-1
Working pressure min./max.	-0,9 ... 10 bar
Control pressure min./max.	See table below
Ambient temperature min./max.	0 ... 80 °C
Medium temperature min./max.	0 ... 80 °C
Medium	Compressed air Class 5-4-4 class 6-4-3
Max. particle size	5 μm
Oil content of compressed air	0 ... 5 mg/m ³
Mounting screw	M6 with hexagon socket
Mounting screw tightening torque	4 Nm
Weight	See table below

Technical data

Part No.		version pneumatic port	Control pressure min./max.	Weight	
0820225103		Base plate ISO 5599-1	1,5 ... 10 bar	0,45 kg	-
0820225104		Base plate ISO 5599-1	2,1 ... 10 bar	0,48 kg	1)

Nominal flow Q_n at 6 bar and $\Delta p = 1$ bar

1) Differential piston, signal 14 has priority

Technical information

The min. control pressure must be adhered to, since otherwise faulty switching and valve failure may result!

The pressure dew point must be at least 15 °C under ambient and medium temperature and may not exceed 3 °C .

The oil content of compressed air must remain constant during the life cycle.

Use only the approved oils from AVENTICS. Further information can be found in the "Technical information" document (available in the MediaCentre).

Technical information

Housing	Polyamide
Seals	Acrylonitrile butadiene rubber

Front plate	Polyamide
-------------	-----------

Dimensions

Dimensions

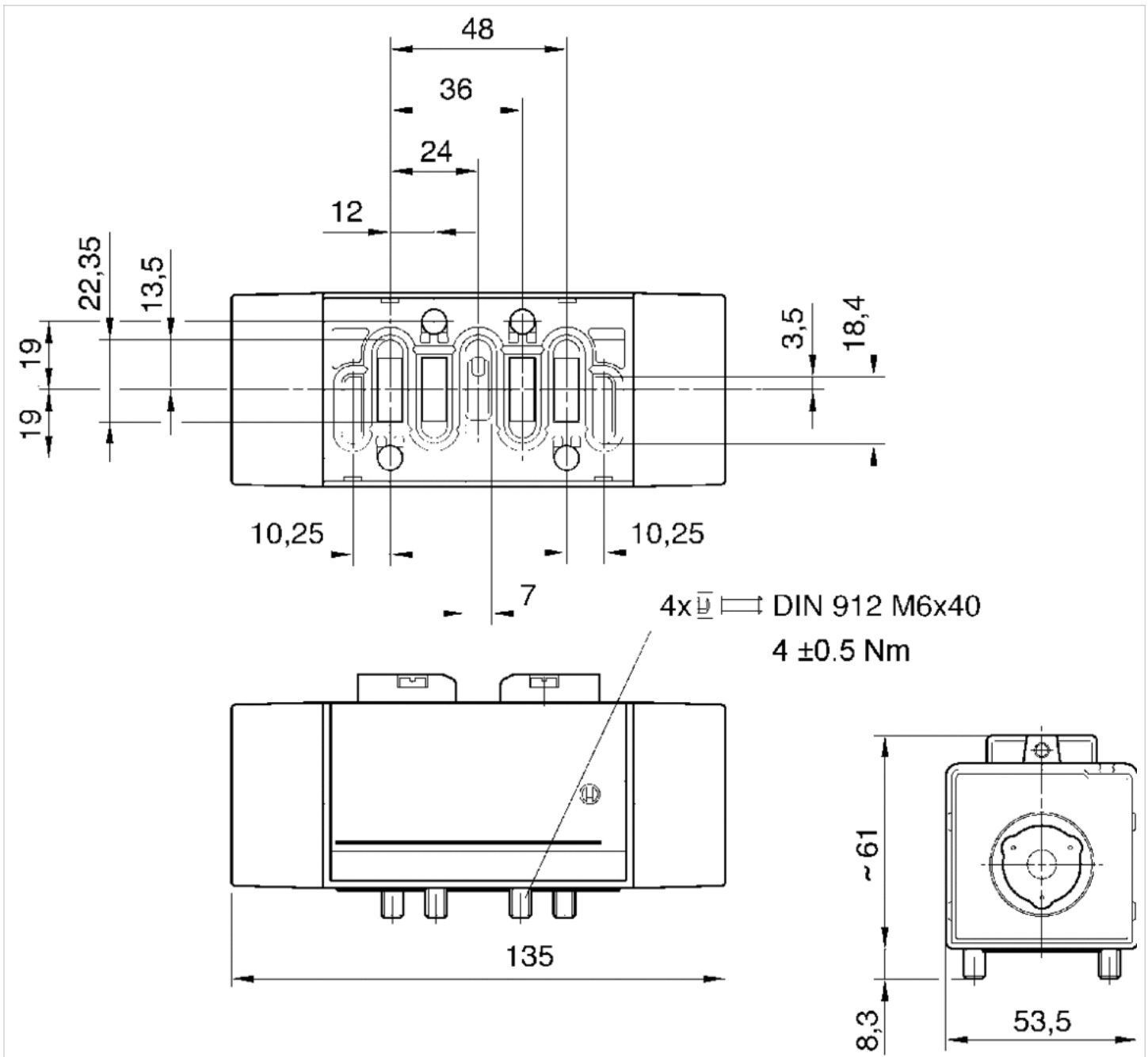





5/3-directional valve, Series IS12, size 2

- Qn = 1700-2400 l/min
- Plate connection
- Compressed air connection output Base plate ISO 5599-1



Type	Spool valve, positive overlapping
Pilot	External
Blocking principle	Single base plate principle
Sealing principle	Soft sealing
Connection type	Plate connection
Standards	ISO 5599-1, ISO 2
Compressed air connection	Base plate ISO 5599-1
version pneumatic port	Base plate ISO 5599-1
Working pressure min./max.	-0,9 ... 10 bar
Control pressure min./max.	2,8 ... 10 bar
Ambient temperature min./max.	0 ... 80 °C
Medium temperature min./max.	0 ... 80 °C
Medium	Compressed air Class 5-4-4 class 6-4-3
Max. particle size	5 µm
Oil content of compressed air	0 ... 5 mg/m ³
Mounting screw	M6 with hexagon socket
Mounting screw tightening torque	4 Nm
Weight	0,51 kg

Technical data

Part No.		version pneumatic port	Flow	
			Qn	
0820228101		closed center	Base plate ISO 5599-1	2400 l/min
0820228102		exhausted center	Base plate ISO 5599-1	1700 l/min
0820228103		pressurized center	Base plate ISO 5599-1	1800 l/min

Nominal flow Qn at 6 bar and $\Delta p = 1$ bar

Technical information

The min. control pressure must be adhered to, since otherwise faulty switching and valve failure may result!
 The pressure dew point must be at least 15 °C under ambient and medium temperature and may not exceed 3 °C .
 The oil content of compressed air must remain constant during the life cycle.
 Use only the approved oils from AVENTICS. Further information can be found in the "Technical information" document (available in the MediaCentre).

Technical information

Housing	Polyamide
Seals	Acrylonitrile butadiene rubber
Front plate	Polyamide

Dimensions

Dimensions

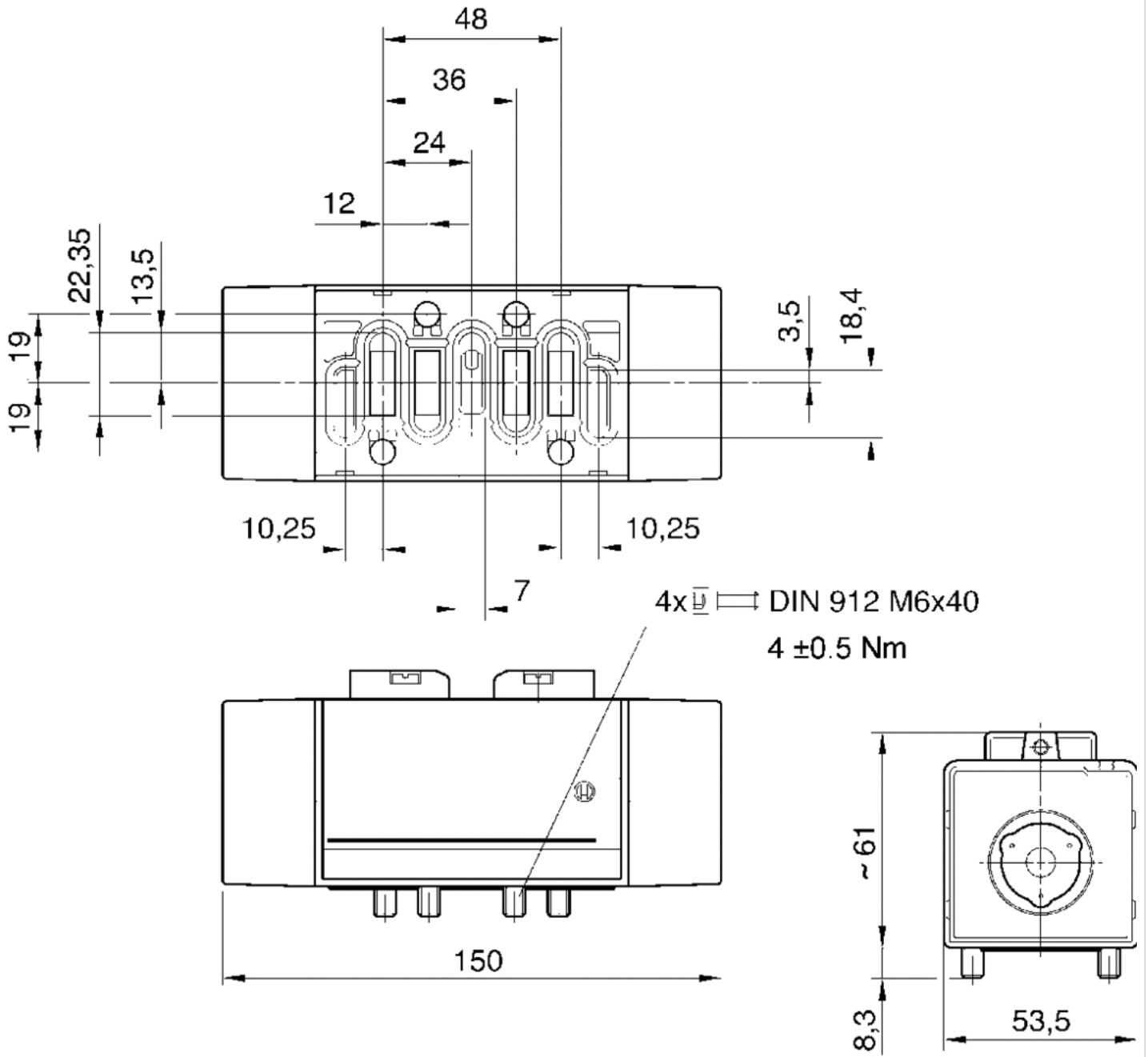

Single subbase, thread connections on the side

- standard ISO 5599-1
- Frame size ISO 2
- Compressed air connection output G 3/8
- Reversed pressure supply permissible



Standards	ISO 5599-1
Working pressure min./max.	-0,95 ... 16 bar
Ambient temperature min./max.	-25 ... 70 °C
Medium temperature min./max.	-25 ... 70 °C
Medium	Compressed air
Number of valve positions max.	1
Grid dimension	57 mm
Direction of pneumatic port (1)	On the side
Direction of pneumatic port (3,5)	On the side
Direction of pneumatic port (2,4)	On the side
Direction of pneumatic port (12)	On the side
Direction of pneumatic port (14)	On the side
Exhaust (3,5)	With directional exhaust (3/5)
Exhaust type	Ports separated
Weight	0,28 kg

Technical data

Part No.	Compressed air connection Input [1]	Compressed air connection Output [2 / 4]
1825503146	G 3/8	G 3/8

Part No.	Compressed air connection Exhaust [3 / 5]	Compressed air connection Pilot connection [12]
1825503146	G 3/8	G 1/8

Part No.	Compressed air connection Pilot control exhaust [R]
1825503146	G 1/8

Technical information

The min. control pressure must be adhered to, since otherwise faulty switching and valve failure may result!
 The pressure dew point must be at least 15 °C under ambient and medium temperature and may not exceed 3 °C .
 The oil content of compressed air must remain constant during the life cycle.
 Use only the approved oils from AVENTICS. Further information can be found in the "Technical information" document (available in the MediaCentre).

For use with HV series valves, the ambient temperature is -25 °C...200 °C and the medium temperature is -25 °C...120 °C.
 Reversed pressure supply is not permitted for HV series valves.

Technical information

Material

Base plate

Die-cast aluminum

Dimensions

Fig. 1

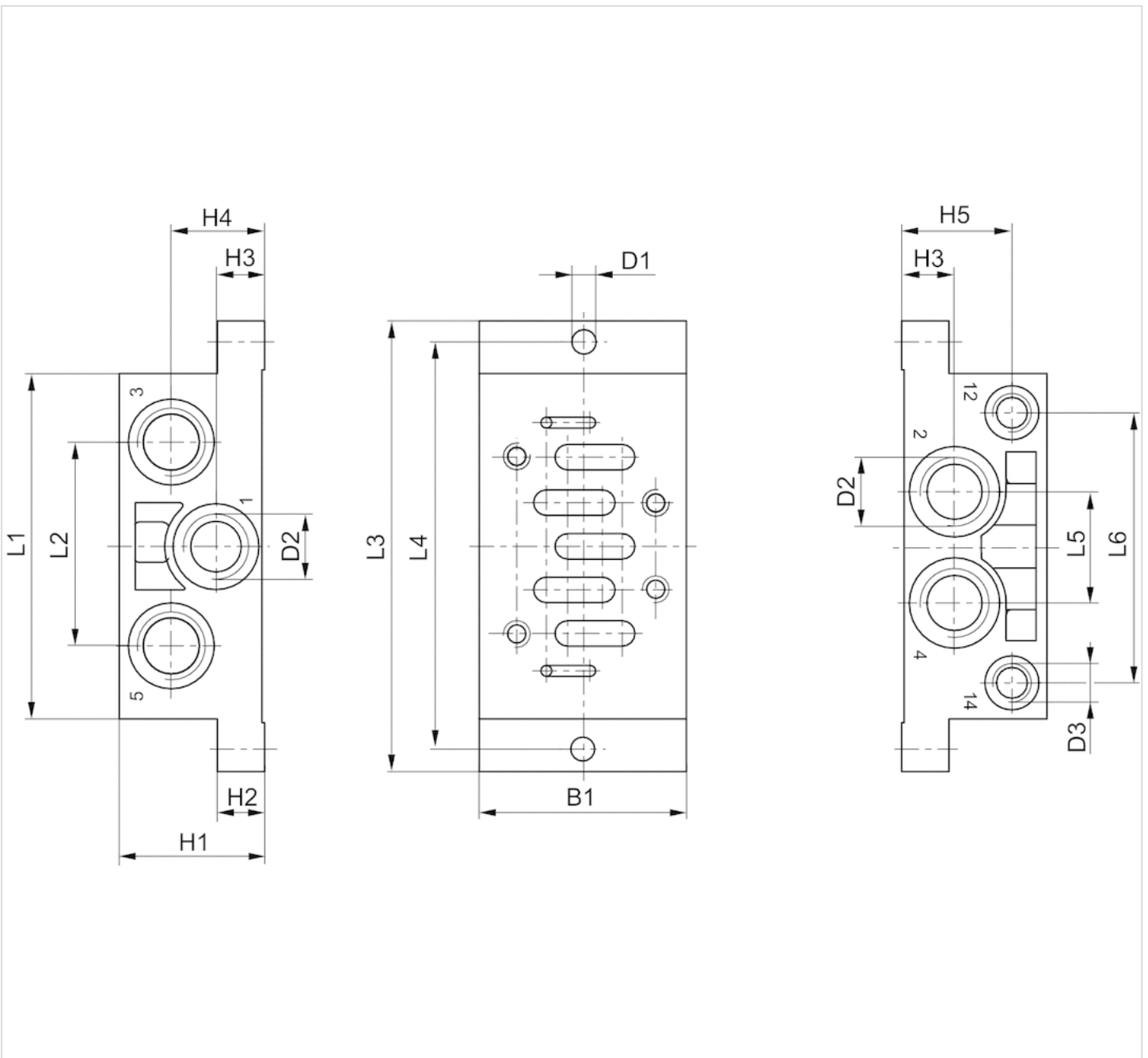

Dimensions

Part No.	Frame size	B1	H1	H2	H3	H4	H5	D1	D2 *)	D3 *)	L1	L2	L3	L4	L5	L6
1825503146	ISO 2	57	40	13	14	26	30	6.6	G 3/8	G 1/8	95	56	124	112	30	74

*) Ports

Single subbase, thread connections on the bottom

- standard ISO 5599-1
- Frame size ISO 2
- Compressed air connection output G 3/8
- Reversed pressure supply permissible



Standards	ISO 5599-1
Working pressure min./max.	-0,95 ... 16 bar
Ambient temperature min./max.	-25 ... 70 °C
Medium temperature min./max.	-25 ... 70 °C
Medium	Compressed air
Number of valve positions max.	1
Direction of pneumatic port (1)	Down
Direction of pneumatic port (3,5)	Down
Direction of pneumatic port (2,4)	Down
Direction of pneumatic port (12)	Down
Direction of pneumatic port (14)	Down
Exhaust (3,5)	With directional exhaust (3/5)
Exhaust type	Ports separated
Weight	0,325 kg

Technical data

Part No.	Compressed air connection Input [1]	Compressed air connection Output [2 / 4]
1825503202	G 3/8	G 3/8

Part No.	Compressed air connection Exhaust [3 / 5]	Compressed air connection Pilot connection [12]
1825503202	G 3/8	G 1/8

Part No.	Compressed air connection Pilot control exhaust [R]
1825503202	G 1/8

Technical information

The min. control pressure must be adhered to, since otherwise faulty switching and valve failure may result!
 The pressure dew point must be at least 15 °C under ambient and medium temperature and may not exceed 3 °C .
 The oil content of compressed air must remain constant during the life cycle.
 Use only the approved oils from AVENTICS. Further information can be found in the "Technical information" document (available in the MediaCentre).

For use with HV series valves, the ambient temperature is -25 °C...200 °C and the medium temperature is -25 °C...120 °C.
 Reversed pressure supply is not permitted for HV series valves.

Technical information

Material

Base plate

Die-cast aluminum

Dimensions

Dimensions

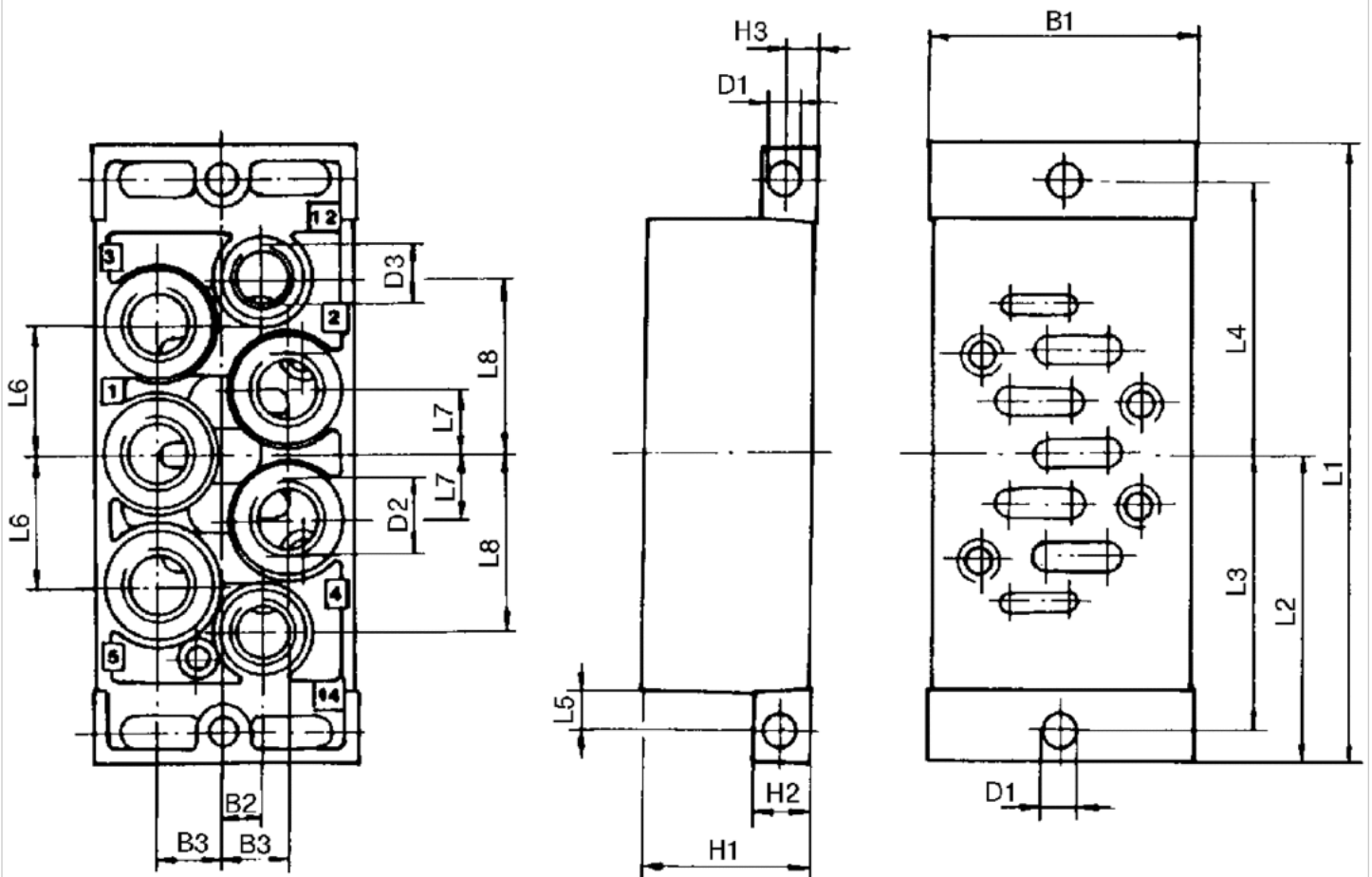

Dimensions

Part No.	Frame size	B1	B2	B3	D1	D2 *)	D3 *)	H1	H2	H3	L1	L2	L3	L4	L5	L6	L7	L8
1825503202	ISO 2	56	8	13,5	6,6	G 3/8	G 1/8	35	13	6,5	124	62	56	56	8,5	28	14	36,5

*) Ports

Single subbase, ports on side

- standard ISO 5599-1
- Frame size ISO 2
- Compressed air connection output G 1/4 G 3/8



Standards	ISO 5599-1
Working pressure min./max.	-1 ... 16 bar
Ambient temperature min./max.	-20 ... 70 °C
Medium temperature min./max.	-20 ... 70 °C
Medium	Compressed air
Number of valve positions max.	1
Direction of pneumatic port (1)	On the side
Direction of pneumatic port (3,5)	On the side
Direction of pneumatic port (2,4)	On the side
Direction of pneumatic port (14)	On the side
Exhaust (3,5)	With directional exhaust (3/5)
Exhaust type	Ports separated
Weight	See table below

Technical data

Part No.	Compressed air connection Input [1]	Compressed air connection Output [2 / 4]
5802710000	G 1/4	G 1/4
5802740000	G 3/8	G 3/8

Part No.	Compressed air connection Exhaust [3 / 5]	Compressed air connection Pilot connection [12]	Weight
5802710000	G 1/4	G 1/8	0,19 kg
5802740000	G 3/8	G 1/8	0,32 kg

Technical information

The min. control pressure must be adhered to, since otherwise faulty switching and valve failure may result!
 The pressure dew point must be at least 15 °C under ambient and medium temperature and may not exceed 3 °C .
 The oil content of compressed air must remain constant during the life cycle.
 Use only the approved oils from AVENTICS. Further information can be found in the "Technical information" document (available in the MediaCentre).

Technical information

Material	
Base plate	Die-cast aluminum, black painted

Dimensions

Dimensions

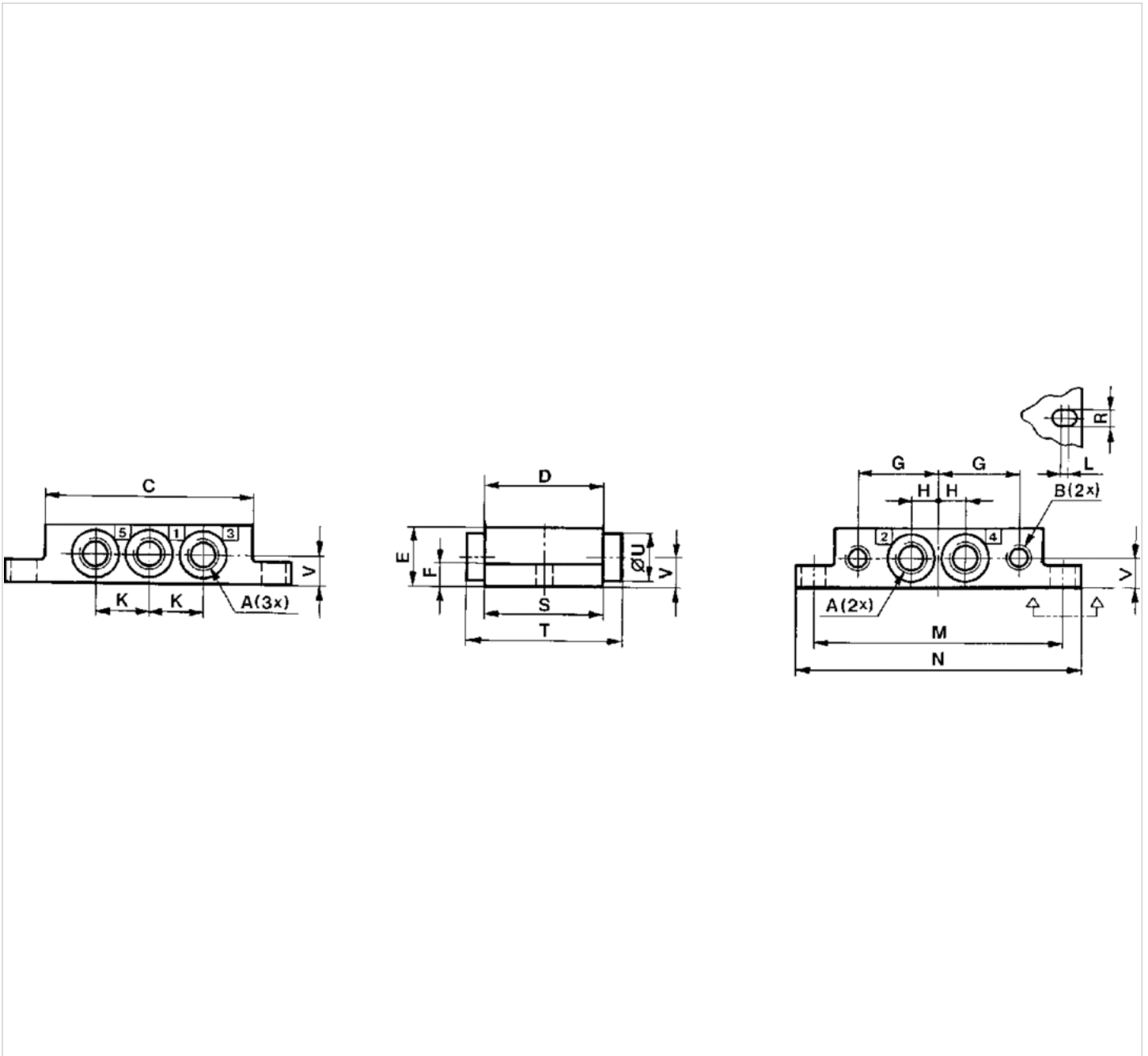

Dimensions

Part No.	Frame size	A *)	B *)	C	D	E	F	G	H	K	L	M	N	R	S	T	U	V
5802710000	ISO 2	G 1/4	G 1/8	86	52	23	8	34	12	24	2	102	115	6.4	52	-	-	11.5
5802740000	ISO 2	G 3/8	G 1/8	86	50	30	13	39	15	30	2	111	124	6.4	56	80	27	16

*) Ports

Single subbase, ports on bottom

- standard ISO 5599-1
- Frame size ISO 2
- Compressed air connection output G 1/4



Standards	ISO 5599-1
Working pressure min./max.	-1 ... 16 bar
Ambient temperature min./max.	-20 ... 70 °C
Medium temperature min./max.	-20 ... 70 °C
Medium	Compressed air
Number of valve positions max.	1
Direction of pneumatic port (1)	Down
Direction of pneumatic port (3,5)	Down
Direction of pneumatic port (2,4)	Down
Direction of pneumatic port (14)	Down
Exhaust (3,5)	uncollected exhaust
Exhaust type	Ports separated
Weight	0,19 kg

Technical data

Part No.	Compressed air connection Input [1]	Compressed air connection Output [2 / 4]
5802700000	G 1/4	G 1/4

Part No.	Compressed air connection Exhaust [3 / 5]	Compressed air connection Pilot connection [12]
5802700000	G 1/4	G 1/8

Technical information

The min. control pressure must be adhered to, since otherwise faulty switching and valve failure may result!
 The pressure dew point must be at least 15 °C under ambient and medium temperature and may not exceed 3 °C .
 The oil content of compressed air must remain constant during the life cycle.
 Use only the approved oils from AVENTICS. Further information can be found in the "Technical information" document (available in the MediaCentre).

Technical information

Material	
Base plate	Die-cast aluminum, black painted

Dimensions

Dimensions

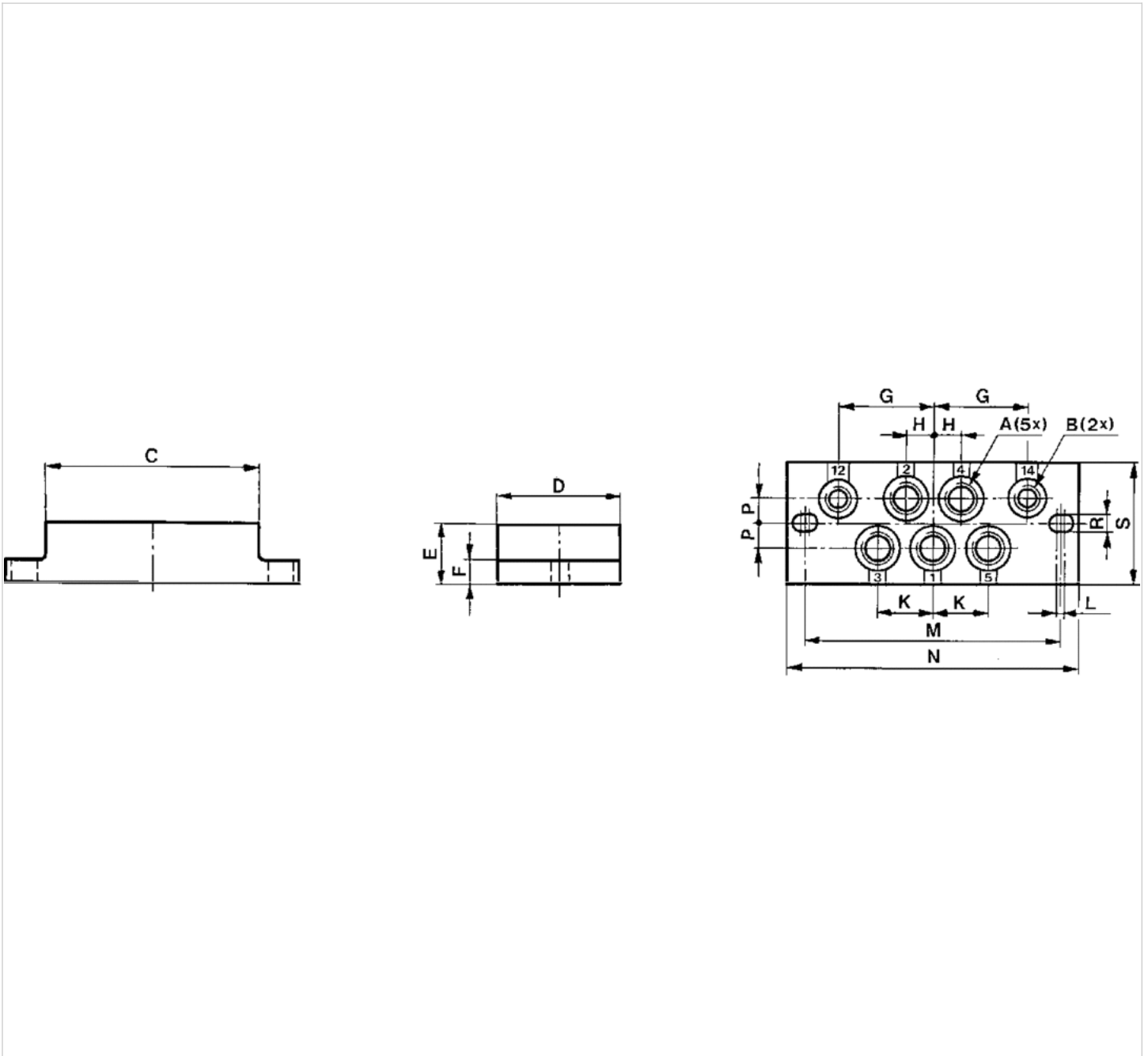

Dimensions

Part No.	Frame size	A *)	B *)	C	D	E	F	G	H	K	L	M	N	P	R	S
5802700000	ISO 2	G1/4	G1/8	86	52	22	8	34	12	24	2	102	115	10	6.4	52

*) Ports

Transition plate

- standard ISO 5599-1
- Frame size ISO 1 ▶ ISO 2
- type F
- Can be assembled into blocks
- Reversed pressure supply permissible



Standards	ISO 5599-1
Working pressure min./max.	-0,95 ... 16 bar
Ambient temperature min./max.	-15 ... 70 °C
Medium temperature min./max.	-15 ... 80 °C
Medium	Compressed air
Exhaust (3,5)	uncollected exhaust
Exhaust type	Ports separated
Mounting screw	hexagon head
Weight	0,295 kg

Technical data

Part No.

1825503164

Technical information

The min. control pressure must be adhered to, since otherwise faulty switching and valve failure may result!
 The pressure dew point must be at least 15 °C under ambient and medium temperature and may not exceed 3 °C .
 The oil content of compressed air must remain constant during the life cycle.
 Use only the approved oils from AVENTICS. Further information can be found in the "Technical information" document (available in the MediaCentre).

Technical information

Material

Housing	Aluminum
Base plate	Aluminum
Seal	Acrylonitrile butadiene rubber

Dimensions

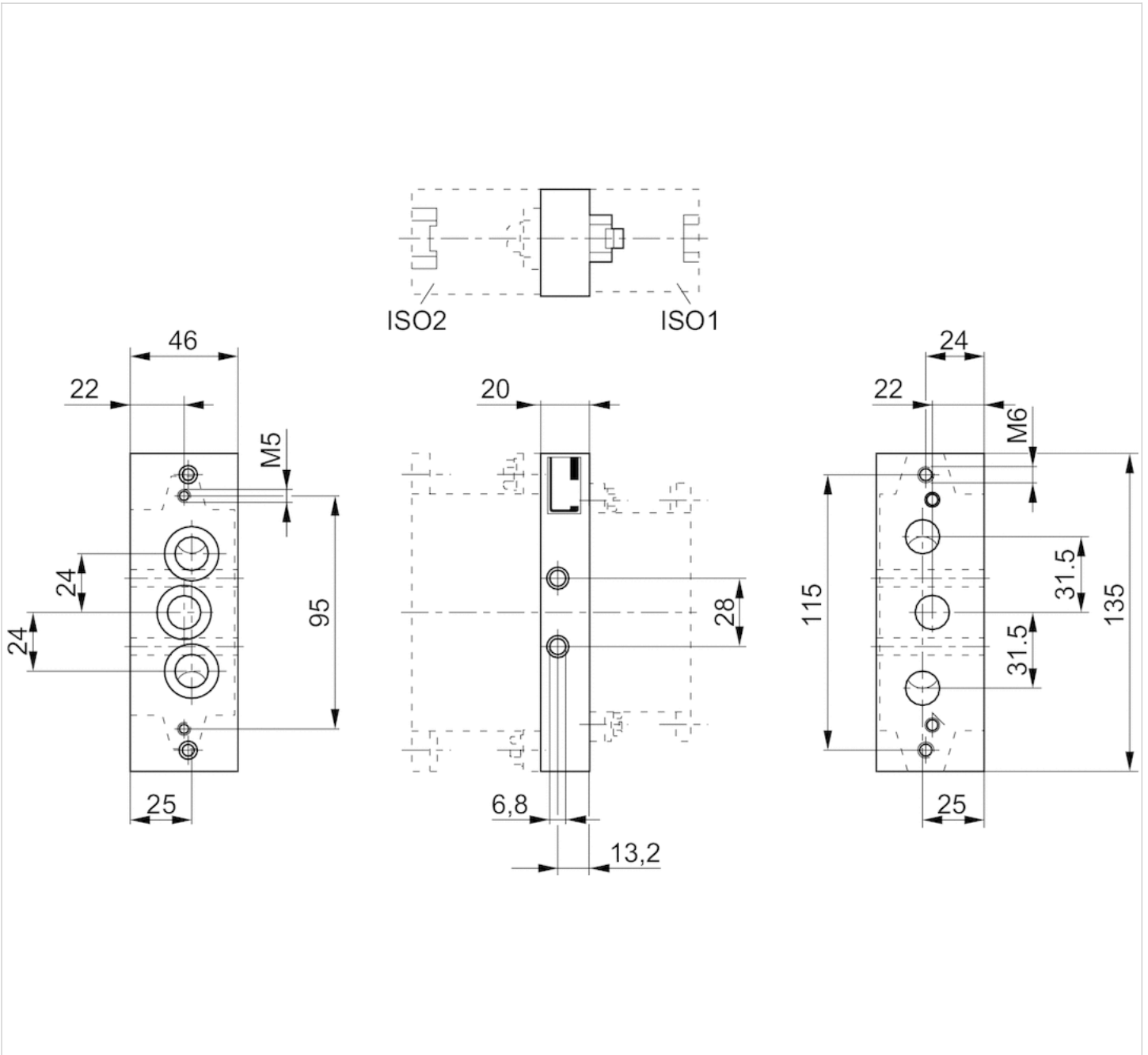

Base plate, ports 2 and 4 on bottom

- standard ISO 5599-1
- Frame size ISO 2
- type F
- Compressed air connection output G 3/8
- Can be assembled into blocks
- Single base plate principle
- Reversed pressure supply permissible
- With collective pilot air exhaust



Standards	ISO 5599-1
Compressed air connection	according to ISO 5599-1
Working pressure min./max.	-0,95 ... 16 bar
Ambient temperature min./max.	-25 ... 70 °C
Medium temperature min./max.	-25 ... 70 °C
Medium	Compressed air
Number of valve positions max.	1
Grid dimension	56 mm
Direction of pneumatic port (1)	On the side
Direction of pneumatic port (3,5)	On the side
Direction of pneumatic port (2,4)	Down
Direction of pneumatic port (12)	On the side
Direction of pneumatic port (14)	On the side
Exhaust (3,5)	With directional exhaust (3/5)
Exhaust type	Ports separated
Mounting screw	hexagon head
Weight	0,378 kg

Technical data

Part No.	Compressed air connection Output [2 / 4]	Compressed air connection Pilot connection [12]
1825503147	G 3/8	G 1/8

Part No.	Compressed air connection Pilot control exhaust [R]
1825503147	G 1/8

Scope of delivery incl. seal and mounting screws

Technical information

The min. control pressure must be adhered to, since otherwise faulty switching and valve failure may result!
 The pressure dew point must be at least 15 °C under ambient and medium temperature and may not exceed 3 °C .
 The oil content of compressed air must remain constant during the life cycle.
 Use only the approved oils from AVENTICS. Further information can be found in the "Technical information" document (available in the MediaCentre).

Technical information

Material	
Housing	Die-cast aluminum
Base plate	Die-cast aluminum
Seal	Acrylonitrile butadiene rubber

Dimensions

Dimensions

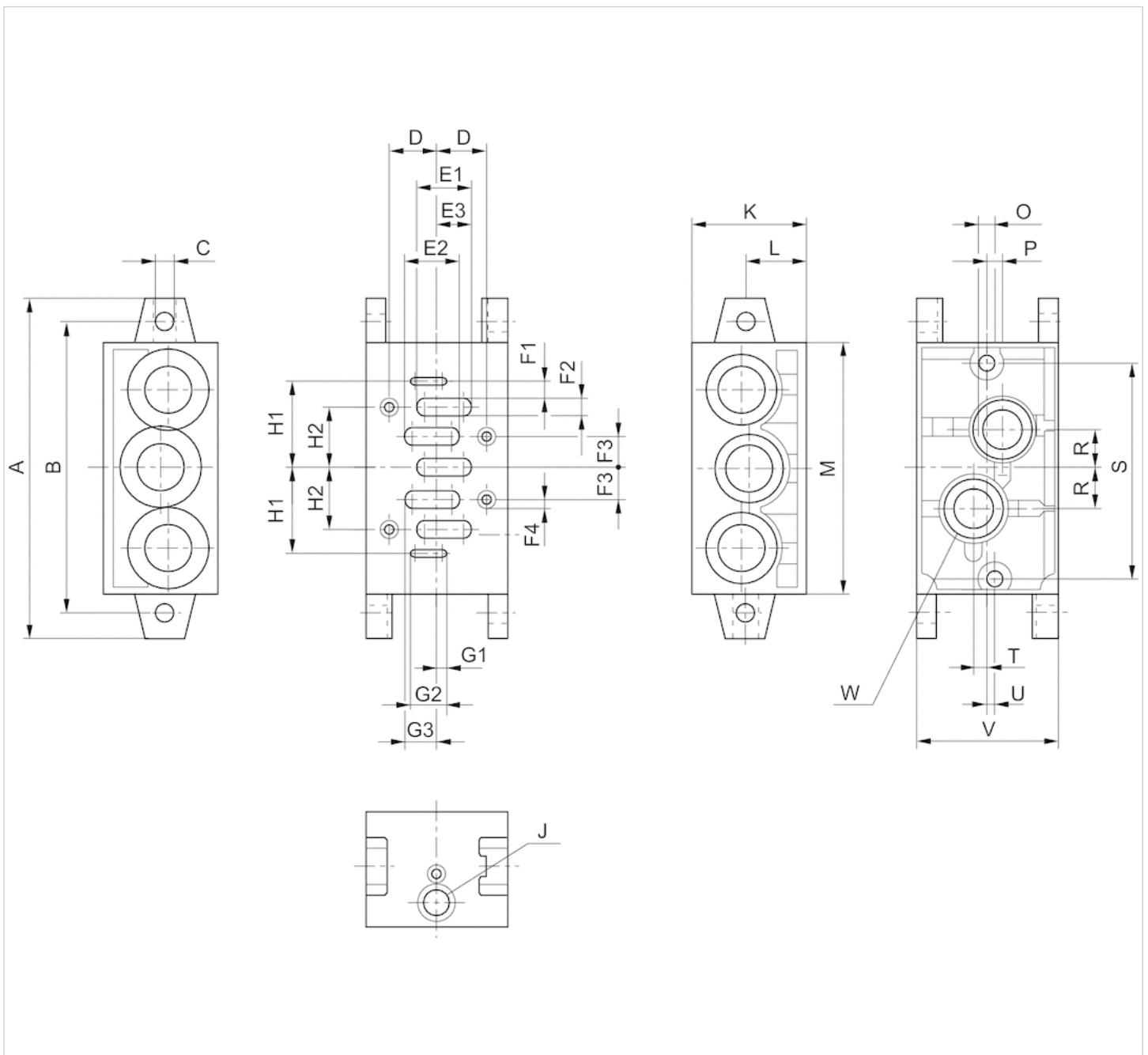

Dimensions

Part No.	A	B	C	D	E1	E2	E3	F1	F2	F3	F4	G1	G2	G3	H1	H2	J	K	L	M	O	P	R
1825503147	135	115	6,6	19	22	22	13,5	3	7	12	M6	3	14,5	13,5	34	24	G 1/8	45	24	100	M6	6	15
S		T				U				V				W									
86		5				3				56				G 3/8									

End plate left, End plate right

- standard ISO 5599-1
- Frame size ISO 2
- type F
- Can be assembled into blocks
- Base plate principle, multiple
- Reversed pressure supply permissible



Standards	ISO 5599-1
Compressed air connection	according to ISO 5599-1
Working pressure min./max.	-0,95 ... 16 bar
Ambient temperature min./max.	-15 ... 70 °C
Medium temperature min./max.	-25 ... 70 °C
Medium	Compressed air
Direction of pneumatic port (1)	On the side
Direction of pneumatic port (3,5)	On the side
Exhaust (3,5)	With directional exhaust (3/5)
Exhaust type	Ports separated
Mounting screw	hexagon head
Weight	0,351 kg

Technical data

Part No.	Compressed air connection	Compressed air connection
	Input [1]	Exhaust [3 / 5]
1825503148	G 1/2	G 1/2

Scope of delivery: 2 end plates including seal and mounting screws

Technical information

The min. control pressure must be adhered to, since otherwise faulty switching and valve failure may result!
 The pressure dew point must be at least 15 °C under ambient and medium temperature and may not exceed 3 °C .
 The oil content of compressed air must remain constant during the life cycle.
 Use only the approved oils from AVENTICS. Further information can be found in the "Technical information" document (available in the MediaCentre).

Technical information

Material	
Base plate	Die-cast aluminum
Seal	Acrylonitrile butadiene rubber

Dimensions

Dimensions

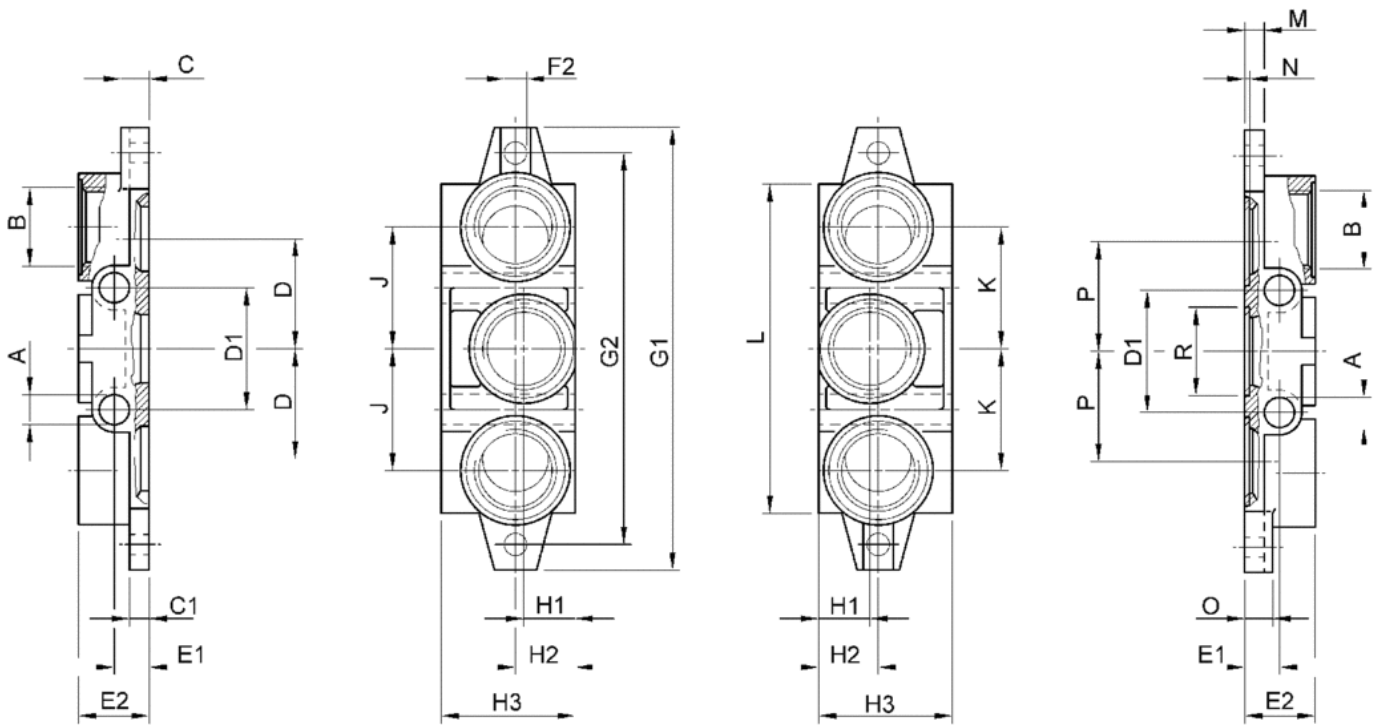

Dimensions

Part No.	A	B	C	C1	D	D1	E1	E2	F2	G1	G2	H1	H2	H3	J	K	L	M	N	O	P	R
1825503148	9	G 1/2	11	8	31,5	35	13	26	Ø 6,6	135	115	23	24	47	34	34	100	8	2	11	31,5	Ø 28,7

End plates for adapter plate

- standard ISO 5599-1
- Frame size ISO 1, ISO 2
- type F
- Can be assembled into blocks
- Reversed pressure supply permissible



Standards	ISO 5599-1
Working pressure min./max.	-0,95 ... 16 bar
Ambient temperature min./max.	-15 ... 70 °C
Medium temperature min./max.	-15 ... 80 °C
Medium	Compressed air
Direction of pneumatic port (1)	On the side
Direction of pneumatic port (3,5)	On the side
Exhaust (3,5)	With directional exhaust (3/5)
Exhaust type	Ports separated
Mounting screw	hexagon head
Weight	0,255 kg

Technical data

Part No.

1825503244

Scope of delivery: 2 end plates of different sizes including seal and mounting screws

Technical information

The min. control pressure must be adhered to, since otherwise faulty switching and valve failure may result!
 The pressure dew point must be at least 15 °C under ambient and medium temperature and may not exceed 3 °C .
 The oil content of compressed air must remain constant during the life cycle.
 Use only the approved oils from AVENTICS. Further information can be found in the "Technical information" document (available in the MediaCentre).

Technical information

Material

Base plate	Die-cast aluminum
Seal	Acrylonitrile butadiene rubber

Dimensions

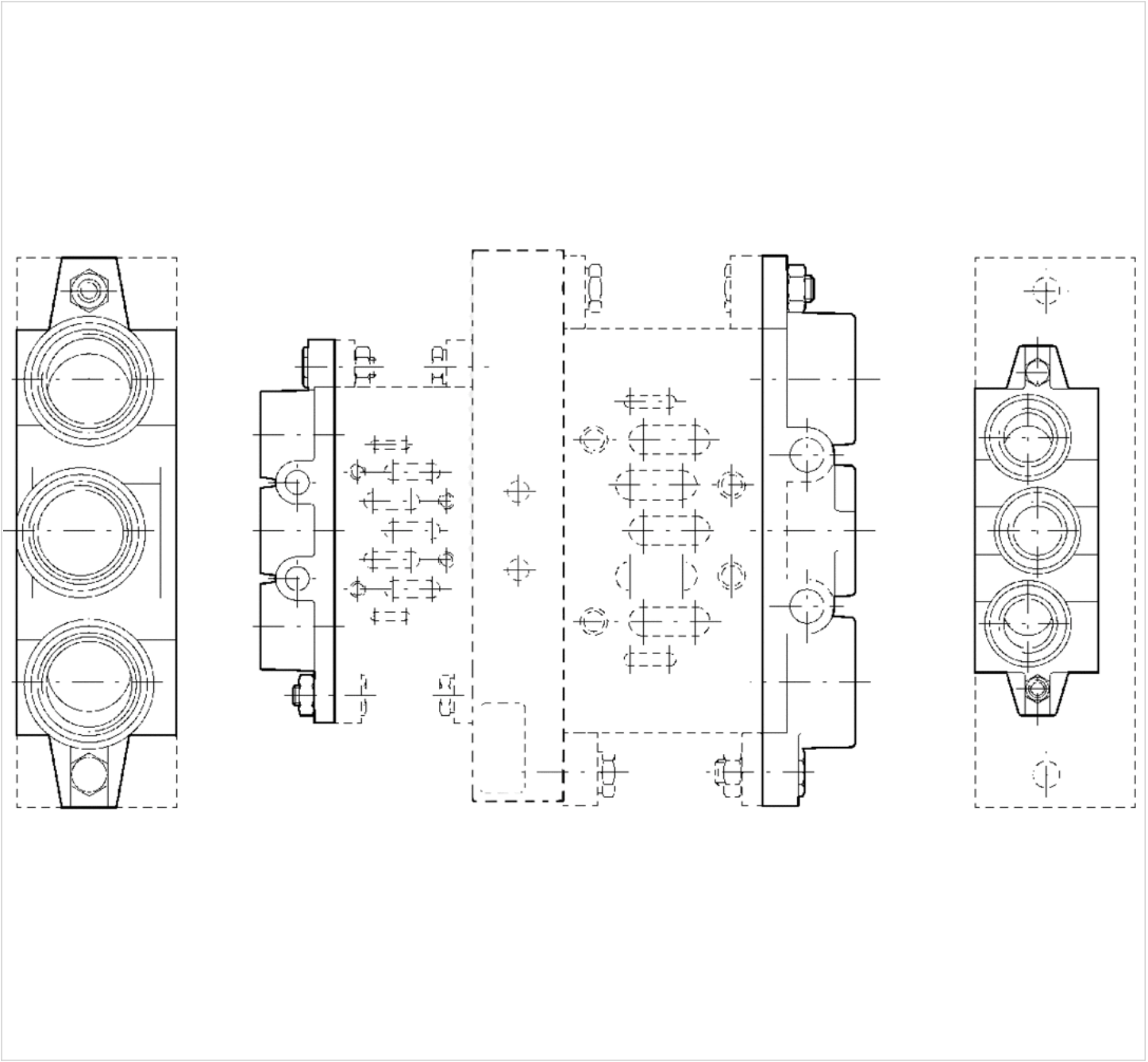

Dimensions

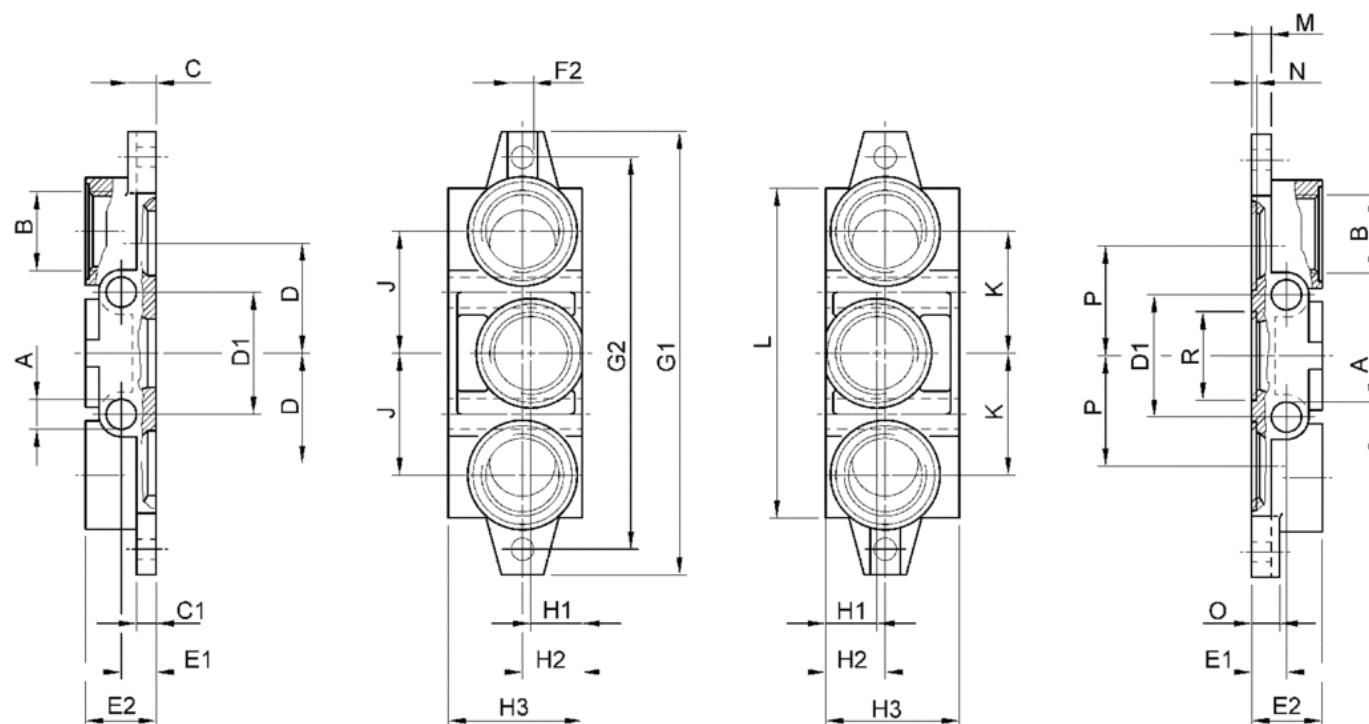

Dimensions

	ISO 1	ISO 2	ISO 3
A	7	9	12
B	G 3/8	G 1/2	G 1
C	8	11	12
C1	6	8	8
D	24	31,5	47
D1	28	35	52
E1	11	13	15
E2	22	26	32
F2	Ø 5,5	Ø 6,6	Ø 9
G1	110	135	190

	ISO 1	ISO 2	ISO 3
G2	95	115	168
H1	22	23	22
H2	22	24	25
H3	46	47	56
J	28	34	52
K	28	34	52
L	85	100	140
M	6	8	8
N	2	2	2,7
O	8	11	12
P	24	31,5	47
R	Ø 22,1	Ø 28,7	Ø 38

Angle subplate

- standard ISO 5599-1
- Frame size ISO 2
- type F
- Compressed air connection output G 3/8



Standards	ISO 5599-1
Working pressure min./max.	0 ... 10 bar
Ambient temperature min./max.	-15 ... 80 °C
Medium temperature min./max.	-15 ... 80 °C
Medium	Compressed air
Direction of pneumatic port (2,4)	On the side
Mounting screw	with hexagon socket
Weight	0,688 kg

Technical data

Part No.	Compressed air connection Output [2 / 4]
1825503204	G 3/8

Technical information

The min. control pressure must be adhered to, since otherwise faulty switching and valve failure may result!
 The pressure dew point must be at least 15 °C under ambient and medium temperature and may not exceed 3 °C .
 The oil content of compressed air must remain constant during the life cycle.
 Use only the approved oils from AVENTICS. Further information can be found in the "Technical information" document (available in the MediaCentre).

Technical information

Material	
Base plate	Aluminum
Seal	Acrylonitrile butadiene rubber

Dimensions

Dimensions

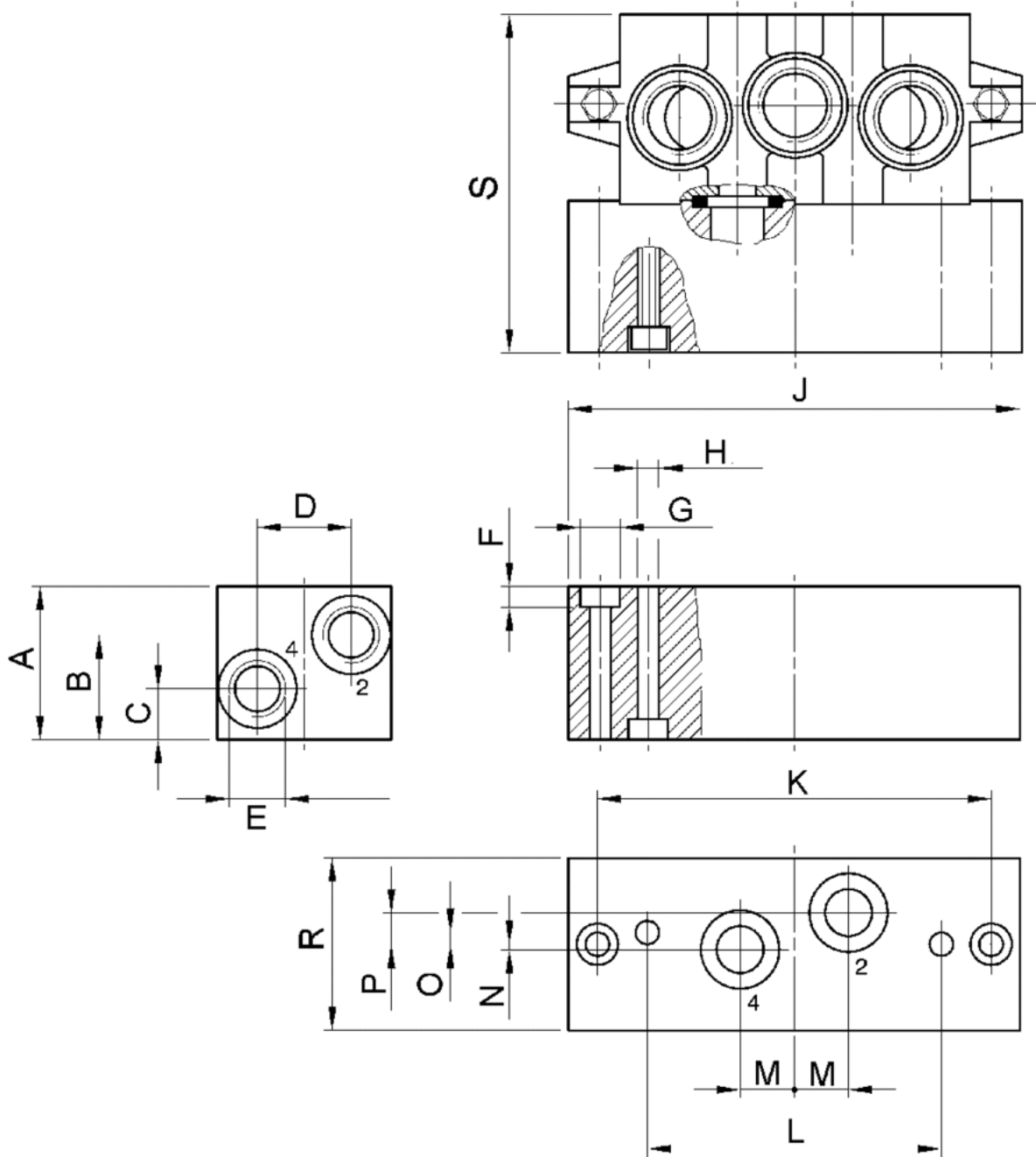

Dimensions

Part No.	A	B	C	D	E	F	G	H	J	K	L	M	N	O	P	R	S
1825503204	40	26	14	29	G 3/8	6,8	Ø 11	Ø 6,6	135	115	86	15	5	3	6	55	85

Blanking piece

- standard ISO 5599-1, ISO 2

- type F



Standards	ISO 5599-1
Ambient temperature min./max.	-15 ... 80 °C
Weight	0,011 kg

Technical data

Part No.	Type	Accessory type	Frame size
1820220023	Blanking piece, ISO 2	type F	ISO 2

Technical information

Material	
Housing	Aluminum
Seal	Acrylonitrile butadiene rubber

Dimensions

Dimensions

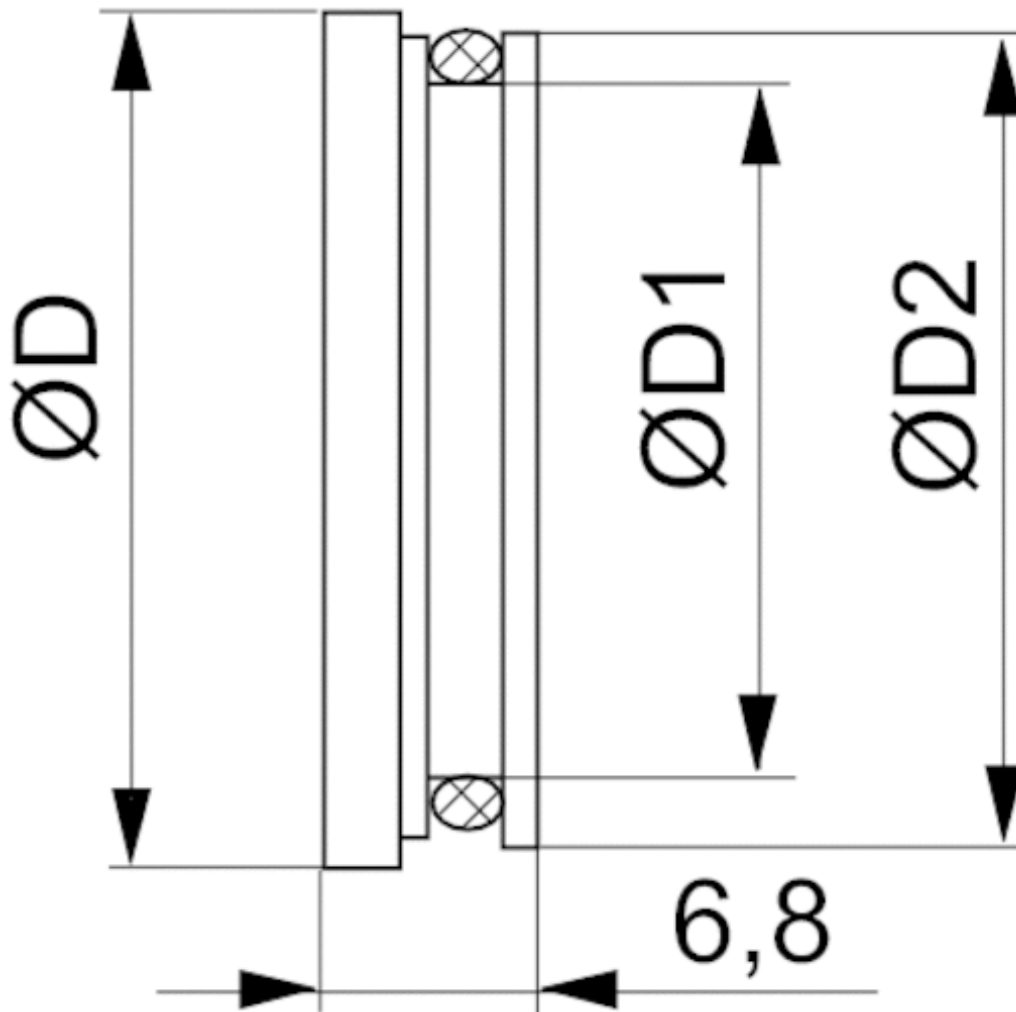

Dimensions

Part No.	Ø D	Ø D1	Ø D2
1820220023	23	14.3	18.2

End plate right

- standard ISO 5599-1
- Frame size ISO 1 ISO 2 ISO 3
- type C



Standards	ISO 5599-1
Working pressure min./max.	-0,95 ... 16 bar
Ambient temperature min./max.	-15 ... 70 °C
Medium temperature min./max.	-15 ... 70 °C
Medium	Compressed air
Weight	See table below

Technical data

Part No.	Frame size	Compressed air connection Input [1]	Compressed air connection Exhaust [3 / 5]	Weight
R432037651	ISO 1	G 3/8	G 3/8	0,32 kg
R432037653	ISO 2	G 3/4	G 3/4	0,491 kg
R432037655	ISO 3	G 1	G 1	1,32 kg

Scope of delivery incl. seal and mounting screws

Technical information

The min. control pressure must be adhered to, since otherwise faulty switching and valve failure may result!
 The pressure dew point must be at least 15 °C under ambient and medium temperature and may not exceed 3 °C .
 The oil content of compressed air must remain constant during the life cycle.
 Use only the approved oils from AVENTICS. Further information can be found in the "Technical information" document (available in the MediaCentre).

Technical information

Material	
Surface	painted
Base plate	Die-cast aluminum, black painted
Seal	Acrylonitrile butadiene rubber

Dimensions

Dimensions

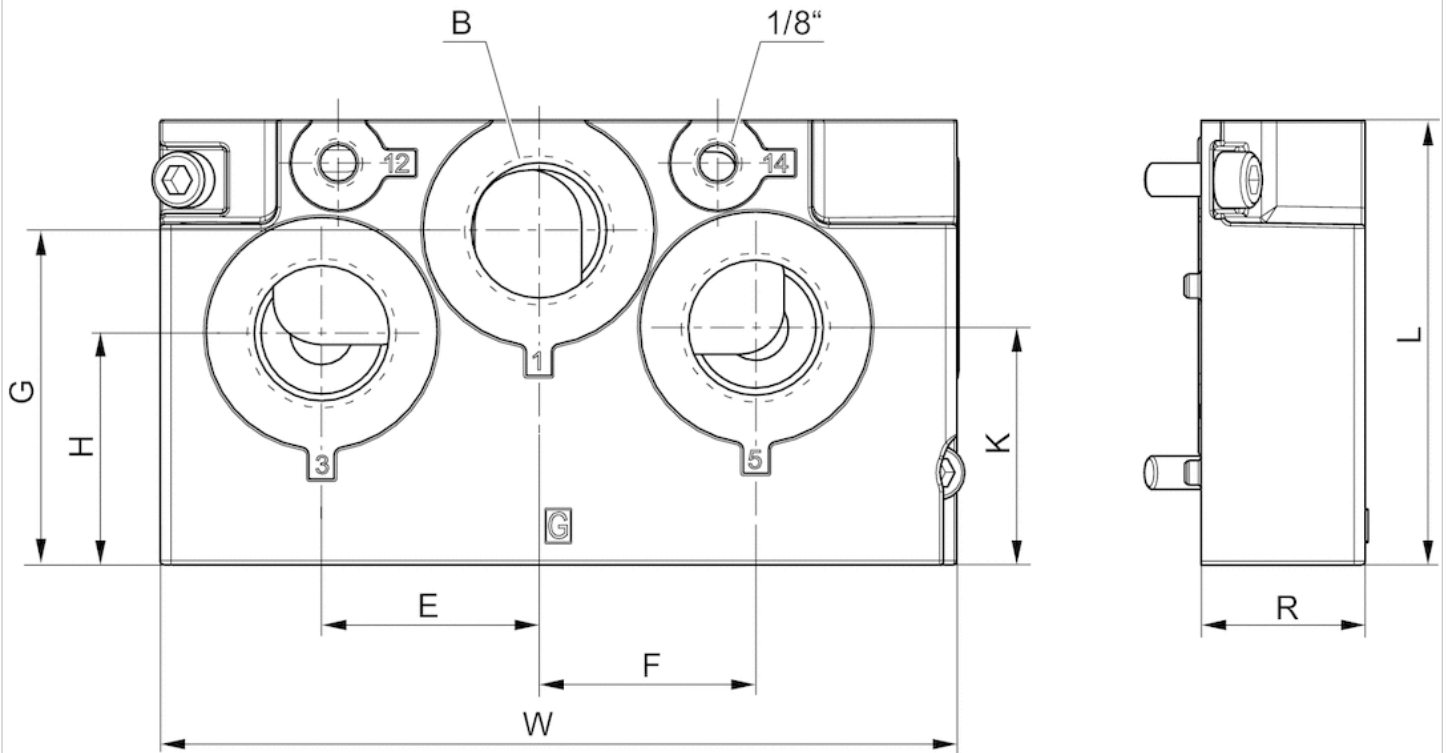

Dimensions

Part No.	Frame size	B	E	F	G	H	J	K	R	L	W
R432037651	ISO 1	3/8	23	18	15.5	30	20	37.5	25	60.6	135
R432037653	ISO 2	3/4	39	39	60	41.5	38	42.5	29.5	79.7	143
R432037655	ISO 3	1	49	49	76	53	32	53	36	100	164

Base plate

- standard ISO 5599-1
- Frame size ISO 1 ISO 2 ISO 3
- type C
- Compressed air connection output G 3/8 G 1/2 G 3/4
- Can be assembled into blocks



Standards	ISO 5599-1
Working pressure min./max.	-1 ... 16 bar
Ambient temperature min./max.	-20 ... 70 °C
Medium temperature min./max.	-20 ... 70 °C
Medium	Compressed air
Direction of pneumatic port (1)	Both directions possible
Direction of pneumatic port (3,5)	Both directions possible
Exhaust type	Ports separated
Weight	See table below

Technical data

Part No.	Frame size	Compressed air connection Output [2 / 4]	Weight
R432037639	ISO 1	G 3/8	0,592 kg
R432037641	ISO 2	G 1/2	1,04 kg
R432037643	ISO 3	G 3/4	1,89 kg

Scope of delivery incl. seal and mounting screws

Technical information

The min. control pressure must be adhered to, since otherwise faulty switching and valve failure may result!

The pressure dew point must be at least 15 °C under ambient and medium temperature and may not exceed 3 °C .

The oil content of compressed air must remain constant during the life cycle.

Use only the approved oils from AVENTICS. Further information can be found in the "Technical information" document (available in the MediaCentre).

Technical information

Material	
Surface	painted
Base plate	Die-cast aluminum, black painted
Seal	Acrylonitrile butadiene rubber

Dimensions

Dimensions

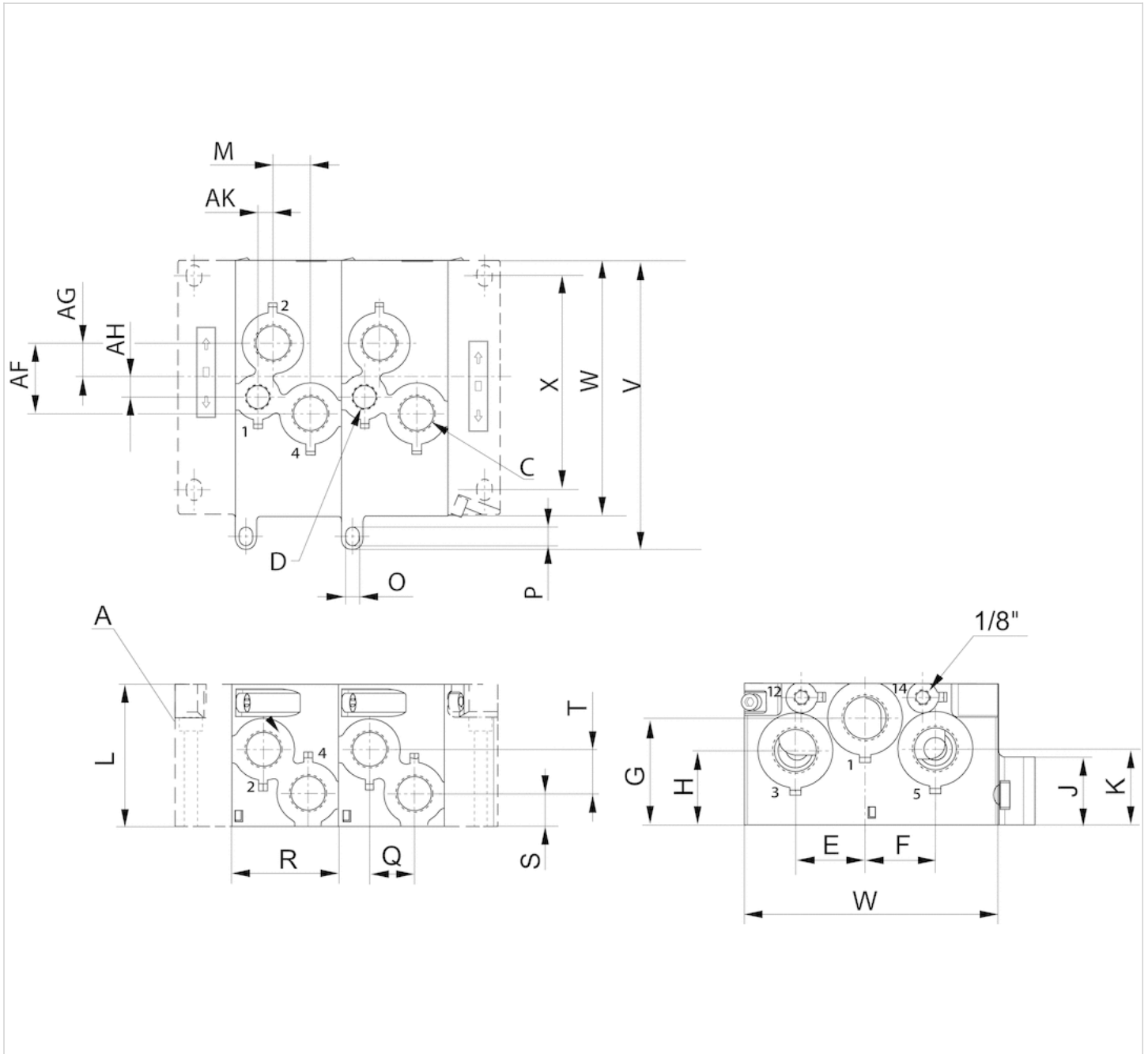

A = left and right end plates in two versions

Dimensions

Part No.	A	D	C	AF	AG	AH	AK	E	F	G	H	J	K	L	M	O	P	R
R432037639	G 1/4	-	G 3/8	23.8	11.8	-	-	23	18	15,5	30	20	37,5	60.6	12	5.5	8.5	45
R432037641	G 1/2	G 3/8	G 1/2	39.5	19	11	8.2	39	39	60	41,5	38	42,5	79.7	21	5.5	9.3	59.5
R432037643	G 3/4	G 1/2	G 3/4	46.3	25.1	11.2	15.8	49	49	76	53	32	53	100	22.5	6.3	9.3	80

Q	S	T	X	W	V
18	13.3	14.7	102,5	135	150

Q	S	T	X	W	V
25	18	24.8	119,6	143	162,5
38	24.5	20.5	99	164	183

End plate left

- standard ISO 5599-1
- Frame size ISO 1 ISO 2 ISO 3
- type C



Standards	ISO 5599-1
Working pressure min./max.	-0,95 ... 16 bar
Ambient temperature min./max.	-15 ... 70 °C
Medium temperature min./max.	-15 ... 70 °C
Medium	Compressed air
Weight	See table below

Technical data

Part No.	Frame size	Compressed air connection Input [1]	Compressed air connection Exhaust [3 / 5]	Weight
R432037645	ISO 1	G 3/8	G 3/8	0,309 kg
R432037647	ISO 2	G 3/4	G 3/4	0,509 kg
R432037649	ISO 3	G 1	G 1	1,31 kg

Scope of delivery incl. seal and mounting screws

Technical information

The min. control pressure must be adhered to, since otherwise faulty switching and valve failure may result!
 The pressure dew point must be at least 15 °C under ambient and medium temperature and may not exceed 3 °C .
 The oil content of compressed air must remain constant during the life cycle.
 Use only the approved oils from AVENTICS. Further information can be found in the "Technical information" document (available in the MediaCentre).

Technical information

Material	
Base plate	Die-cast aluminum
Seal	Acrylonitrile butadiene rubber

Dimensions

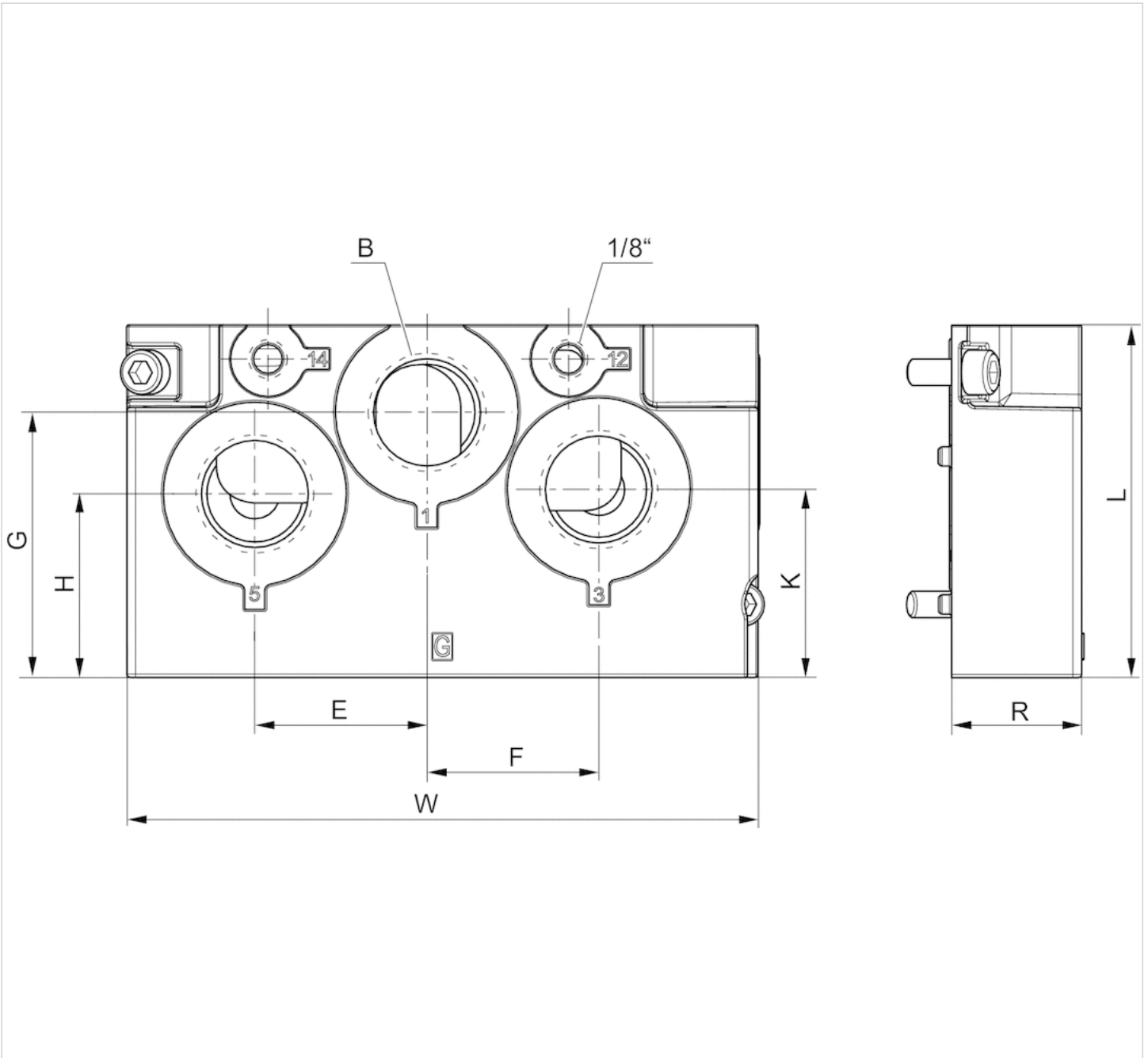

Dimensions

Part No.	Frame size	B	E	F	G	H	J	K	L	R	W
R432037645	ISO 1	3/8	23	18	15.5	30	20	37.5	60.6	25	135
R432037647	ISO 2	3/4	39	39	60	41.5	38	42.5	79.7	32	143
R432037649	ISO 3	1	49	49	76	53	32	53	100	37	164

Blanking piece

- according to ISO 5599

- standard ISO 1 ISO 2 ISO 3

- type C



Weight

See table below

Technical data

Part No.	Type	Accessory type	Frame size	Weight
R432038306	Blanking piece	type C	ISO 1	0,009 kg
R432037662	Blanking piece	type C	ISO 2	0,009 kg
R432037663	Blanking piece	type C	ISO 3	0,02 kg

Base plate, ports 2 and 4 on bottom

- standard ISO 5599-1
- Frame size ISO 2
- type K
- Compressed air connection output G 3/8
- Can be assembled into blocks



Standards	ISO 5599-1
Working pressure min./max.	-1 ... 16 bar
Ambient temperature min./max.	-20 ... 70 °C
Medium temperature min./max.	-20 ... 70 °C
Medium	Compressed air
Number of valve positions max.	1
Direction of pneumatic port (2,4)	Down
Exhaust (3,5)	uncollected exhaust
Exhaust type	Ports separated
Weight	0,52 kg

An example configuration is illustrated.
The delivered product may thus deviate from the illustration.

Technical data

Part No.	Compressed air connection Output [2 / 4]	Compressed air connection Pilot connection [12]
5802750000	G 3/8	G 1/8

Scope of delivery incl. seal and mounting screws

Technical information

The min. control pressure must be adhered to, since otherwise faulty switching and valve failure may result!
The pressure dew point must be at least 15 °C under ambient and medium temperature and may not exceed 3 °C .
The oil content of compressed air must remain constant during the life cycle.
Use only the approved oils from AVENTICS. Further information can be found in the "Technical information" document (available in the MediaCentre).

Technical information

Material	
Base plate	Die-cast aluminum, black painted
Seal	Acrylonitrile butadiene rubber

Dimensions

Dimensions

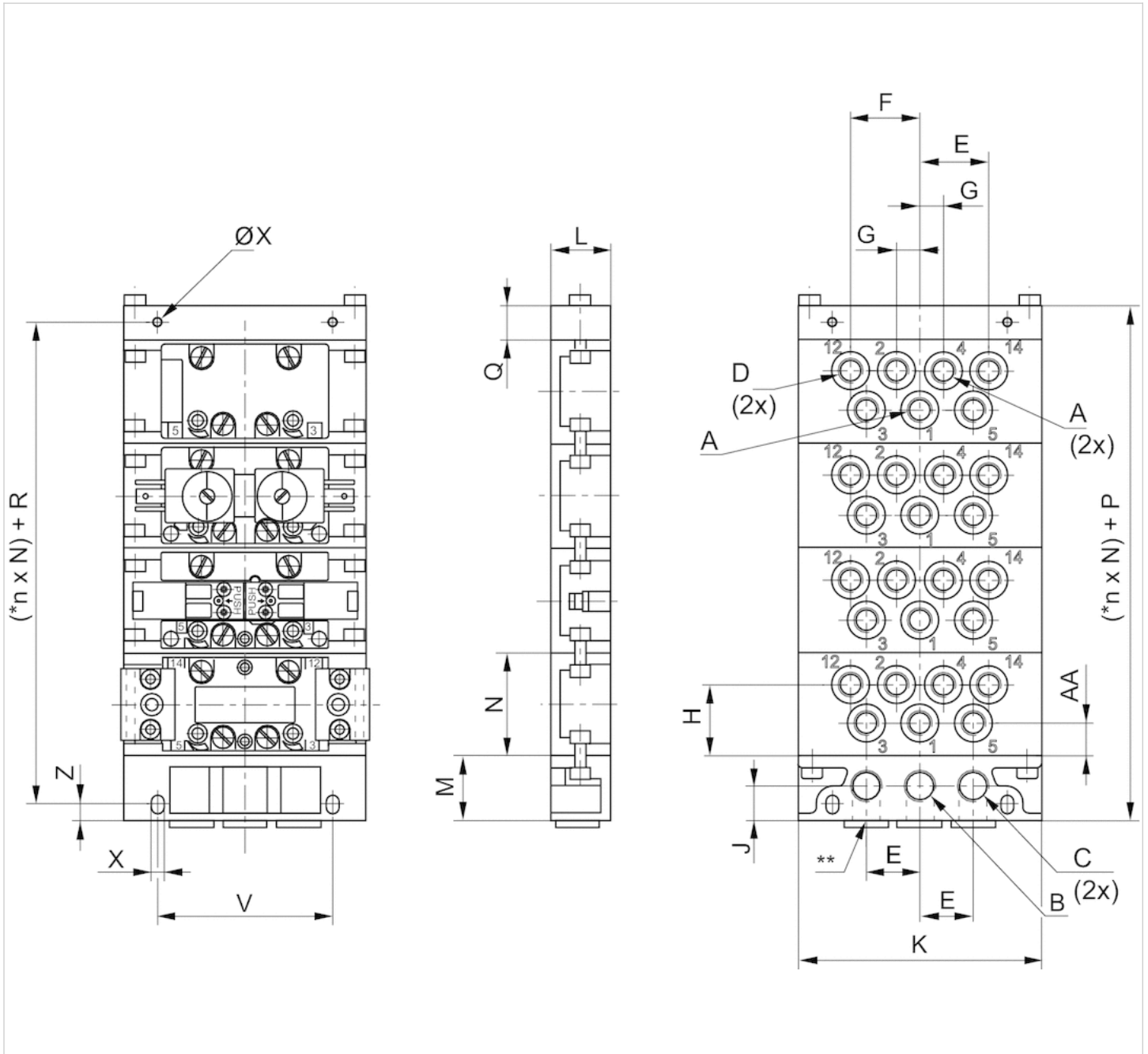

* n = Number of subbases.

** Alternative port openings, closed with plugs

Dimensions

Part No.	*	A	B	C	D	E	F	G	H	J	K	L	M	N	P	Q	R	V	X	Z	
5802750000	c	ISO 2	G 3/8	G 1/2	G 1/2	G 1/8	36	52	17	33	22	156	37	39	56	59	20	40	118	8.4	10

AA																				
13																				

* Intermediate plates designated with the same letters (a-d) can be mounted together without a transition plate.

Intermediate plate for separate air supply, ports 2 and 4 on bottom

- standard ISO 5599-1
- Frame size ISO 2
- type K
- Compressed air connection output G 1/4 G 3/8
- Can be assembled into blocks



Standards	ISO 5599-1
Working pressure min./max.	-1 ... 16 bar
Ambient temperature min./max.	-20 ... 70 °C
Medium temperature min./max.	-20 ... 70 °C
Medium	Compressed air
Number of valve positions max.	1
Direction of pneumatic port (1)	Down
Direction of pneumatic port (3,5)	Down
Direction of pneumatic port (2,4)	Down
Direction of pneumatic port (14)	Down
Exhaust (3,5)	uncollected exhaust
Exhaust type	Ports separated
Weight	See table below

An example configuration is illustrated. The delivered product may thus deviate from the illustration.

Technical data

Part No.	Type	Compressed air connection Input [1]
5802670000	Intermediate plate for separate air supply	G 1/4
5802680000	Intermediate plate for separate air supply	G 3/8

Part No.	Compressed air connection Output [2 / 4]	Compressed air connection Pilot connection [12]	Port	Weight
5802670000	G 1/4	G 1/8	-	0,27 kg
5802680000	G 3/8	G 1/8	G 3/8	0,52 kg

Scope of delivery incl. seal and mounting screws

Technical information

The min. control pressure must be adhered to, since otherwise faulty switching and valve failure may result!

The pressure dew point must be at least 15 °C under ambient and medium temperature and may not exceed 3 °C .

The oil content of compressed air must remain constant during the life cycle.

Use only the approved oils from AVENTICS. Further information can be found in the "Technical information" document (available in the MediaCentre).

Technical information

Material

Base plate	Die-cast aluminum, black painted
Seal	Acrylonitrile butadiene rubber

Dimensions

Dimensions

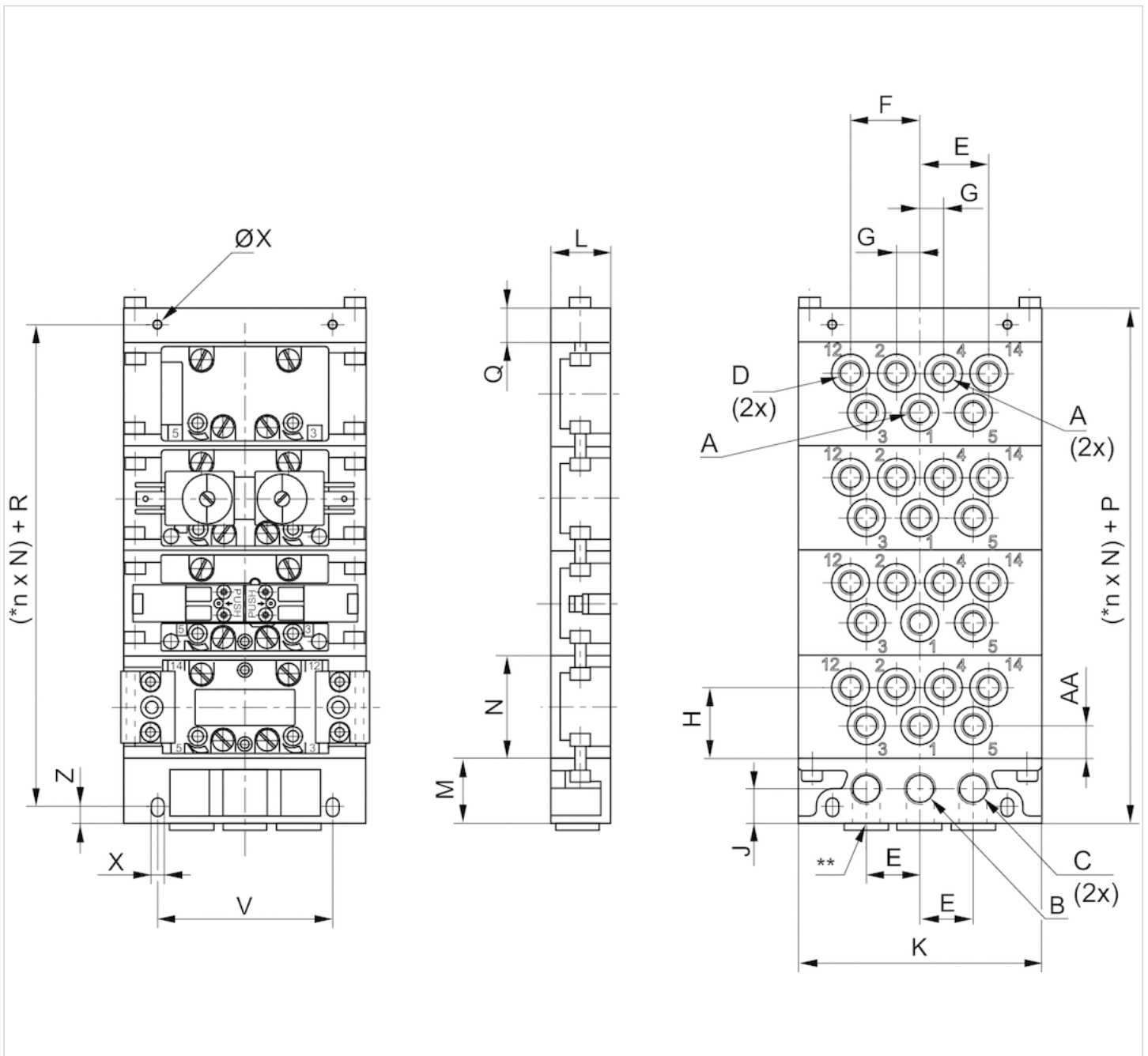

* n = Number of subbases.

** Alternative port openings, closed with plugs

Dimensions

Part No.		A	B	C	D	E	F	G	H	J	K	L	M	N	P	Q	R	V	X	Z
5802670000	ISO 2	G 1/4	G 3/8	G 3/8	G 1/8	27	39	13.5	38	20	122	28	34	56	49	15	34	94	6.4	8
5802680000	ISO 2	G 3/8	G 1/2	G 1/2	G 1/8	36	52	17	33	22	156	37	39	56	59	20	40	118	8.4	10

AA																				
18																				
33																				

End plate left, End plate right

- standard ISO 5599-1
- Frame size ISO 1, ISO 2
- type K
- Can be assembled into blocks

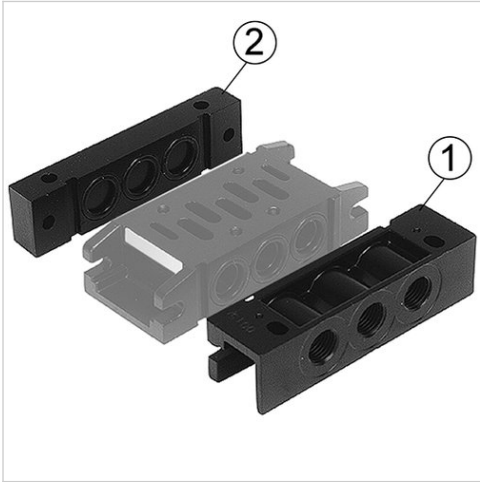

Standards	ISO 5599-1
Working pressure min./max.	-1 ... 16 bar
Ambient temperature min./max.	-20 ... 70 °C
Medium temperature min./max.	-20 ... 70 °C
Medium	Compressed air
Exhaust (3,5)	uncollected exhaust
Exhaust type	Ports separated
Weight	See table below

An example configuration is illustrated.
The delivered product may thus deviate from the illustration.

Technical data

Part No.	Compressed air connection Input [1]	Compressed air connection Exhaust [3 / 5]	Weight
5802850000	G 3/8	G 3/8	0,26 kg
5802860000	-	-	0,13 kg

Technical information

The min. control pressure must be adhered to, since otherwise faulty switching and valve failure may result!
The pressure dew point must be at least 15 °C under ambient and medium temperature and may not exceed 3 °C .
The oil content of compressed air must remain constant during the life cycle.
Use only the approved oils from AVENTICS. Further information can be found in the "Technical information" document (available in the MediaCentre).

Technical information

Material	
Surface	painted
Base plate	Die-cast aluminum, black painted
Seal	Acrylonitrile butadiene rubber

Dimensions

Dimensions

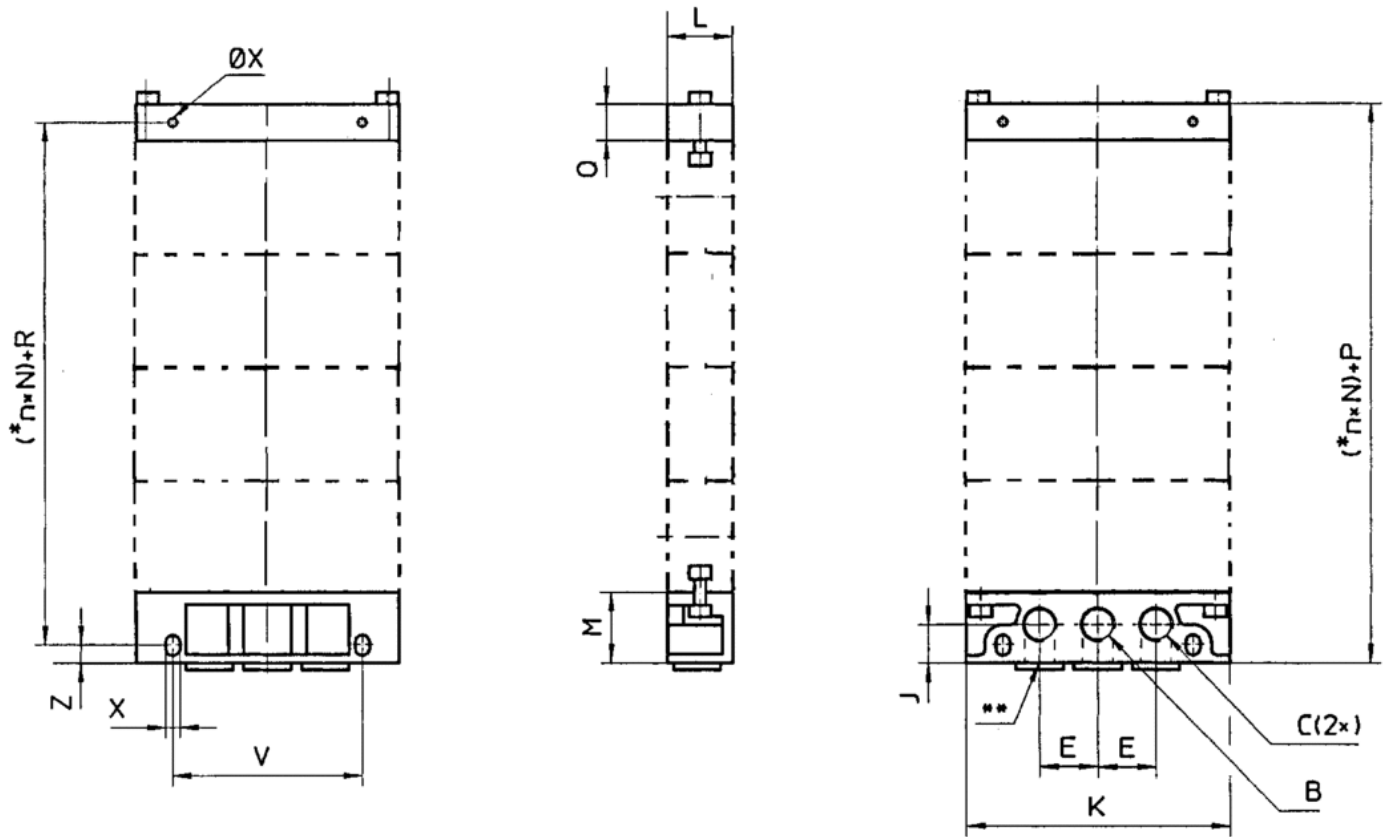

* n = Number of subbases.

** Alternative port openings, closed with plugs

Dimensions

Part No.		B	C	E	J	K	L	M	P	Q	R	V	X	Z	Weight
5802850000	ISO 1 , ISO 2	G 3/8	G 3/8	27	20	122	30	34	49	-	34	94	6.4	8	0,26 kg
5802860000	ISO 1 , ISO 2	-	-	-	-	122	29	-	49	15	34	94	6.4	-	0,13 kg

Separator set

- standard ISO 5599-1, ISO 1 ISO 2

- type K



Standards

ISO 5599-1

Ambient temperature min./max.

-20 ... 70 °C

Weight

0,017 kg

An example configuration is illustrated.
The delivered product may thus deviate from the illustration.

Technical data

Part No.	Type	Accessory type	Frame size	Delivery unit
5802880000	b	type K	ISO 1, ISO 2	3 piece

Technical information

Material	
Housing	Brass

Dimensions

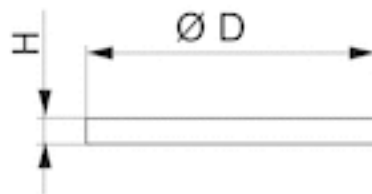

Dimensions

Part No.	D	H
5802880000	17,2	2

Blanking piece, Subbases ISO 5599-1

- standard ISO 5599-1, ISO 1 ISO 5599-1, ISO 2 ISO 5599-1, ISO 3

- type F



Standards

ISO 5599-1

Working pressure min./max.

-0,95 ... 10 bar

Ambient temperature min./max.

-25 ... 70 °C

Technical data

Part No.	Accessory type	Frame size
8985049012	type F	ISO 1
8985049022	type F	ISO 2
8985049032	type F	ISO 3

Technical information

Material	
Housing	Brass
Seal	Acrylonitrile butadiene rubber

Dimensions

Dimensions

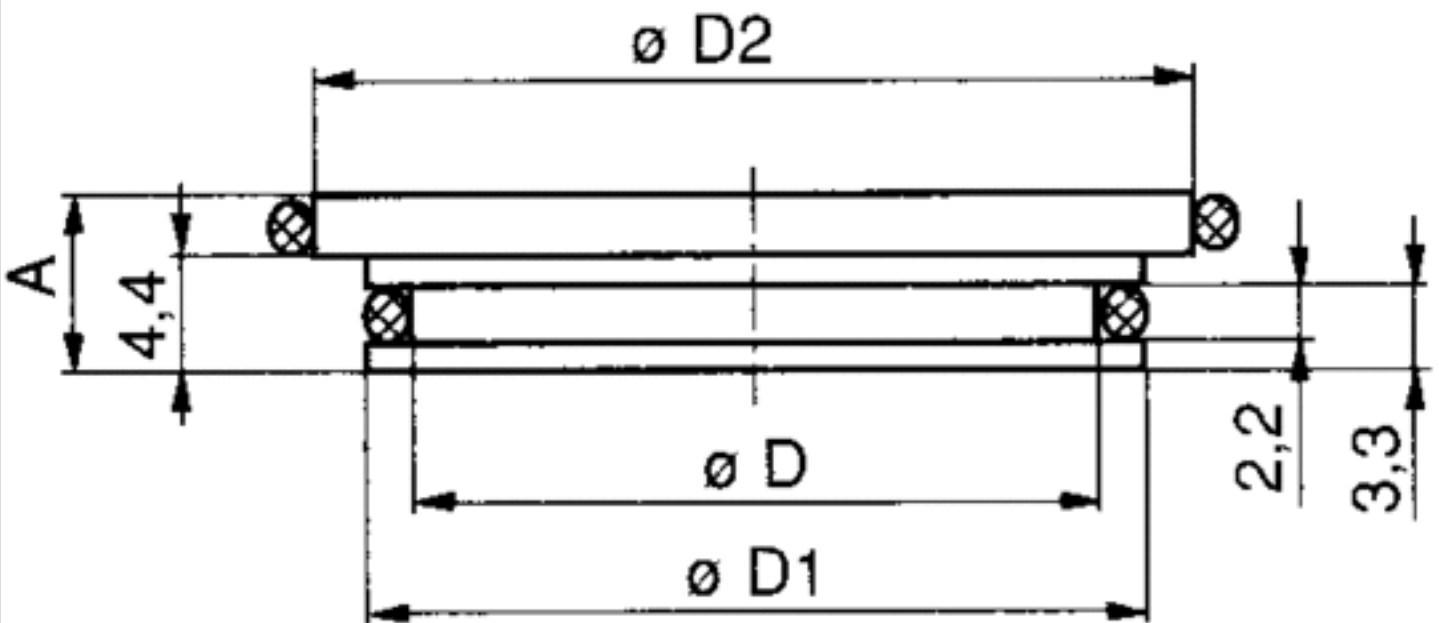

Dimensions

Part No.	Frame size	A	D	D1	D2
8985049012	ISO 1	6.2	12.2	14.8	16.5
8985049022	ISO 2	6.2	15.7	18.3	23
8985049032	ISO 3	6.9	25.1	27.7	30

Base plate, Ports 2 and 4 side or bottom

- standard ISO 5599-1
- Frame size ISO 2
- type G
- Compressed air connection output G 3/8
- Can be assembled into blocks



Standards	ISO 5599-1
Working pressure min./max.	-1 ... 16 bar
Ambient temperature min./max.	-20 ... 70 °C
Medium temperature min./max.	-20 ... 70 °C
Medium	Compressed air
Number of valve positions max.	1
Direction of pneumatic port (2,4)	Both directions possible
Direction of pneumatic port (14)	Down
Exhaust (3,5)	uncollected exhaust
Exhaust type	Ports separated
Weight	0,36 kg

An example configuration is illustrated.
The delivered product may thus deviate from the illustration.

Technical data

Part No.	Compressed air connection Input [1]	Compressed air connection Output [2 / 4]
5802500000	G 3/8	G 3/8

Part No.	Compressed air connection Pilot connection [12]
5802500000	G 1/8

Scope of delivery incl. seal and mounting screws

Technical information

The min. control pressure must be adhered to, since otherwise faulty switching and valve failure may result!
The pressure dew point must be at least 15 °C under ambient and medium temperature and may not exceed 3 °C .
The oil content of compressed air must remain constant during the life cycle.
Use only the approved oils from AVENTICS. Further information can be found in the "Technical information" document (available in the MediaCentre).

Technical information

Material	
Base plate	Die-cast aluminum
Seal	Acrylonitrile butadiene rubber

Dimensions

Dimensions

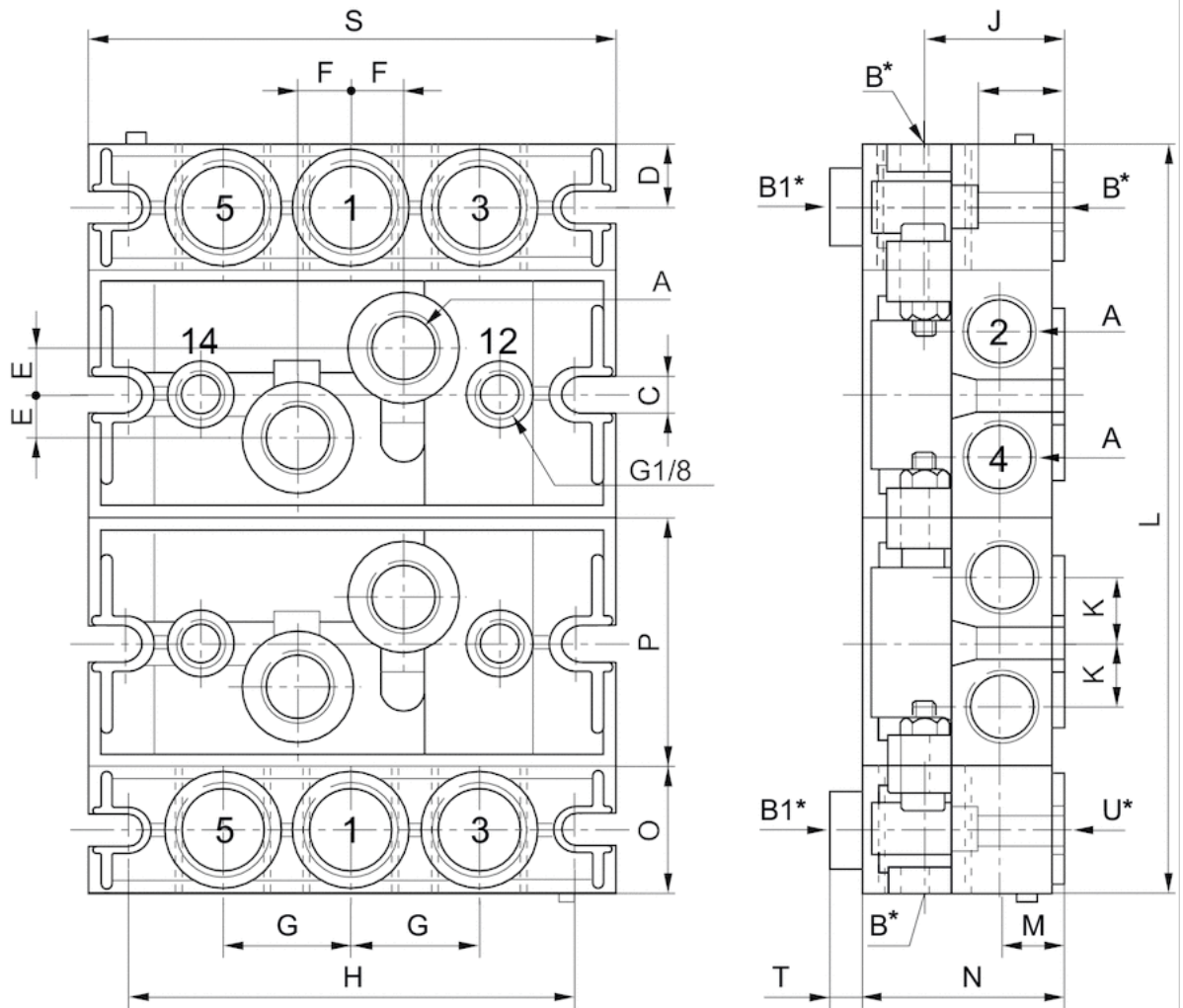

Dimensions

Part No.		A	B	B1	C	D	E	F	G	H	J	K	L
5802500000	ISO 2	2 x G 3/8	3 x G 1/2	3 x G 3/8	6.5	14.5	10	12	29	102	32	15	n x 56 + 58
M	N	O	P	R	S	T							
15	45.7	29	56	20	120	7							

n = number of subbases

End plate left, End plate right

- standard ISO 5599-1
- Frame size ISO 2
- type G
- Can be assembled into blocks
- Base plate principle, multiple
- Reversed pressure supply permissible



Standards	ISO 5599-1
Compressed air connection	according to ISO 5599-1
Working pressure min./max.	-1 ... 16 bar
Ambient temperature min./max.	-20 ... 70 °C
Medium temperature min./max.	-20 ... 70 °C
Medium	Compressed air
Direction of pneumatic port (1)	Both directions possible
Direction of pneumatic port (3,5)	Both directions possible
Exhaust (3,5)	uncollected exhaust
Exhaust type	Ports separated
Weight	0,46 kg

An example configuration is illustrated. The delivered product may thus deviate from the illustration.

Technical data

Part No.	Compressed air connection	
	Input [1]	Exhaust [3 / 5]
5802510000	G 1/2	G 1/2

Delivered in pairs with all ports closed. Porting can be in end, top, or bottom (both ends). Porting is selected by drilling through dimensions B*, B1*, or U* on drawing below., Scope of delivery incl. seal and mounting screws

Technical information

The min. control pressure must be adhered to, since otherwise faulty switching and valve failure may result!
 The pressure dew point must be at least 15 °C under ambient and medium temperature and may not exceed 3 °C .
 The oil content of compressed air must remain constant during the life cycle.
 Use only the approved oils from AVENTICS. Further information can be found in the "Technical information" document (available in the MediaCentre).

Technical information

Material	
Base plate	Die-cast aluminum
Seal	Acrylonitrile butadiene rubber

Dimensions

Dimensions

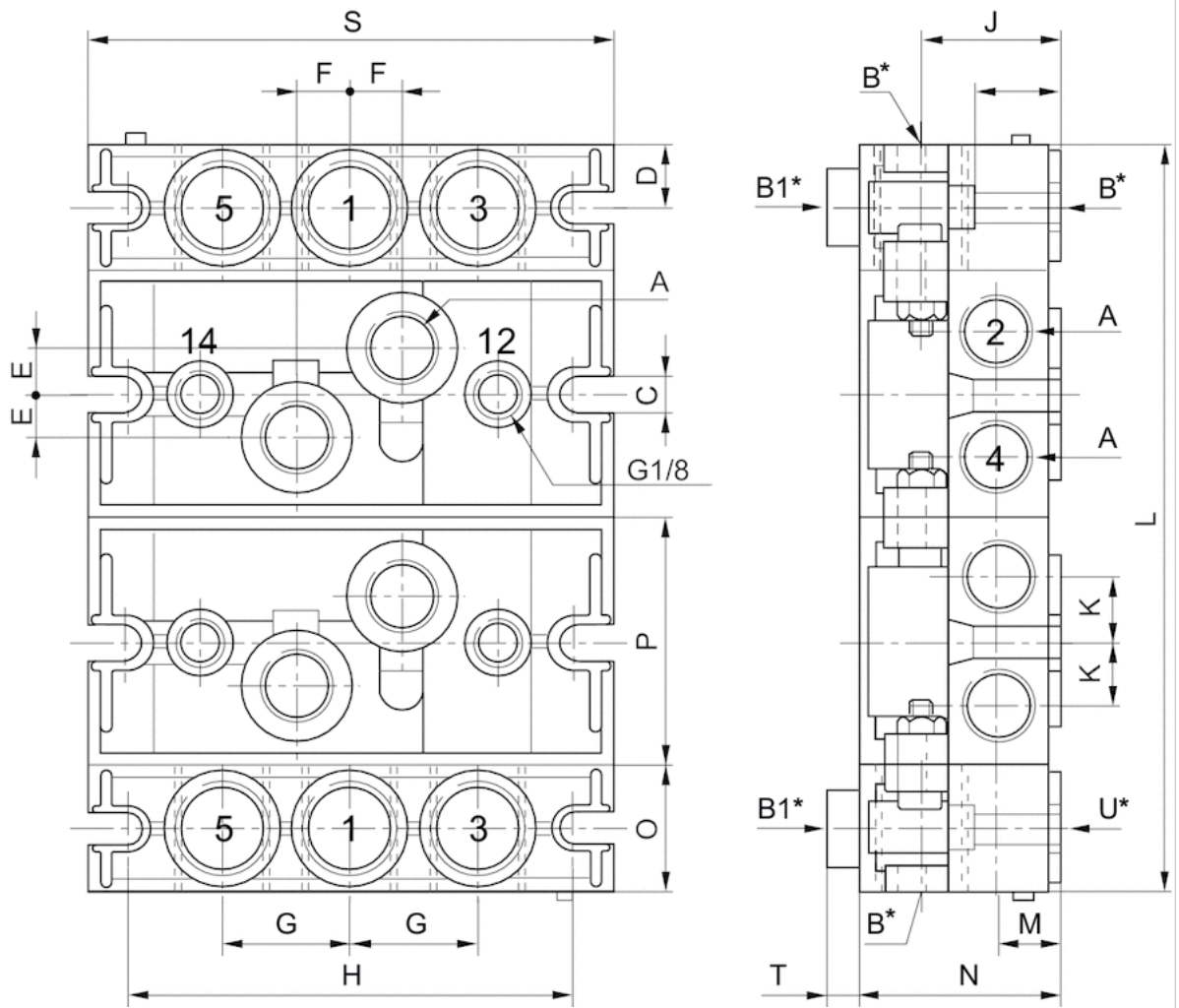

Dimensions

Part No.		A	B*	B1*	C	D	E	F	G	H	J	K	L
5802510000	ISO 2	2 x G 3/8	3 x G 1/2	3 x G 1/4	6.5	14.5	10	12	29	102	32	15	n x 56 + 58

M	N	O	P	R	S	T	U*
15	43	29	56	20	120	7	3 x G 1/2

n = number of subbases

*Dimensions B, B1, and U are prepared with threaded connections but must be drilled through as required for the desired porting configuration.

Transition plate

- standard ISO 5599-1
- Frame size ISO 1, ISO 2
- type G
- Can be assembled into blocks
- Reversed pressure supply permissible



Standards	ISO 5599-1
Working pressure min./max.	-1 ... 16 bar
Ambient temperature min./max.	-20 ... 70 °C
Medium temperature min./max.	-20 ... 70 °C
Medium	Compressed air
Exhaust (3,5)	uncollected exhaust
Exhaust type	Ports separated
Weight	0,27 kg

Technical data

Part No.

5802520000

Scope of delivery incl. seal and mounting screws

Technical information

The min. control pressure must be adhered to, since otherwise faulty switching and valve failure may result!
 The pressure dew point must be at least 15 °C under ambient and medium temperature and may not exceed 3 °C .
 The oil content of compressed air must remain constant during the life cycle.
 Use only the approved oils from AVENTICS. Further information can be found in the "Technical information" document (available in the MediaCentre).

The transition plate is used for combining subbases of different sizes in the same manifold.

Technical information

Material	
Surface	painted
Base plate	Die-cast aluminum, black painted
Seal	Acrylonitrile butadiene rubber

Dimensions

Dimensions

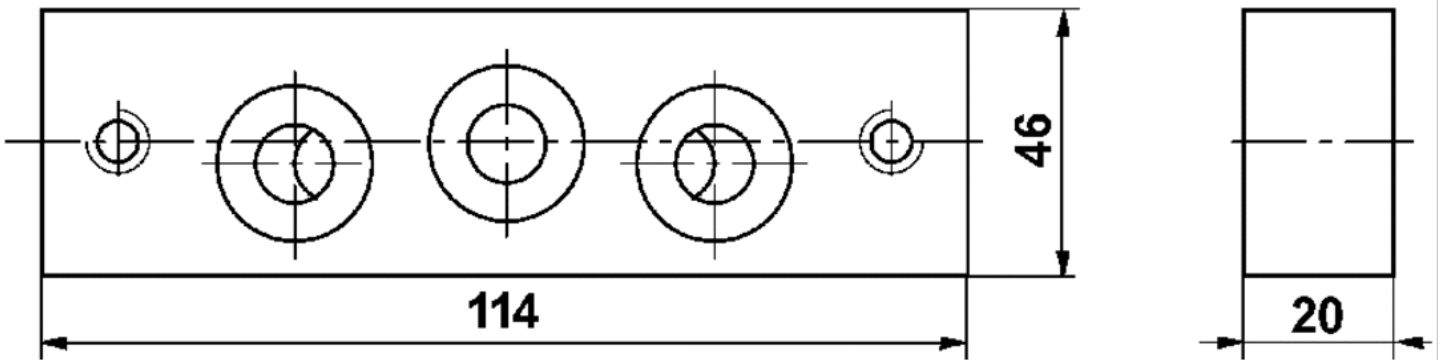

Blanking piece

- standard ISO 5599-1

- type G



Standards

ISO 5599-1

Ambient temperature min./max.

-20 ... 70 °C

Weight

0,025 kg

Technical data

Part No.	Accessory type
5802530000	type G

Technical information

Material	
Housing	Brass
Seal	Acrylonitrile butadiene rubber

Blanking plate

- standard ISO 5599-1
- Frame size ISO 2



Standards	ISO 5599-1
Working pressure min./max.	-0,9 ... 16 bar
Ambient temperature min./max.	0 ... 80 °C
Medium temperature min./max.	0 ... 80 °C
Medium	Compressed air
Mounting screw	with hexagon socket
Weight	See table below

Technical data

Part No.	Type	Frame size	Weight
1825503176	Blanking plate	ISO 2	0,229 kg
1821A15032	Gasket ISO 2	-	-

Scope of delivery incl. seal and mounting screws

Technical information

The min. control pressure must be adhered to, since otherwise faulty switching and valve failure may result!
 The pressure dew point must be at least 15 °C under ambient and medium temperature and may not exceed 3 °C .
 The oil content of compressed air must remain constant during the life cycle.
 Use only the approved oils from AVENTICS. Further information can be found in the "Technical information" document (available in the MediaCentre).

Technical information

Material	
Base plate	Aluminum Die-cast aluminum
Seal	Acrylonitrile butadiene rubber

Dimensions

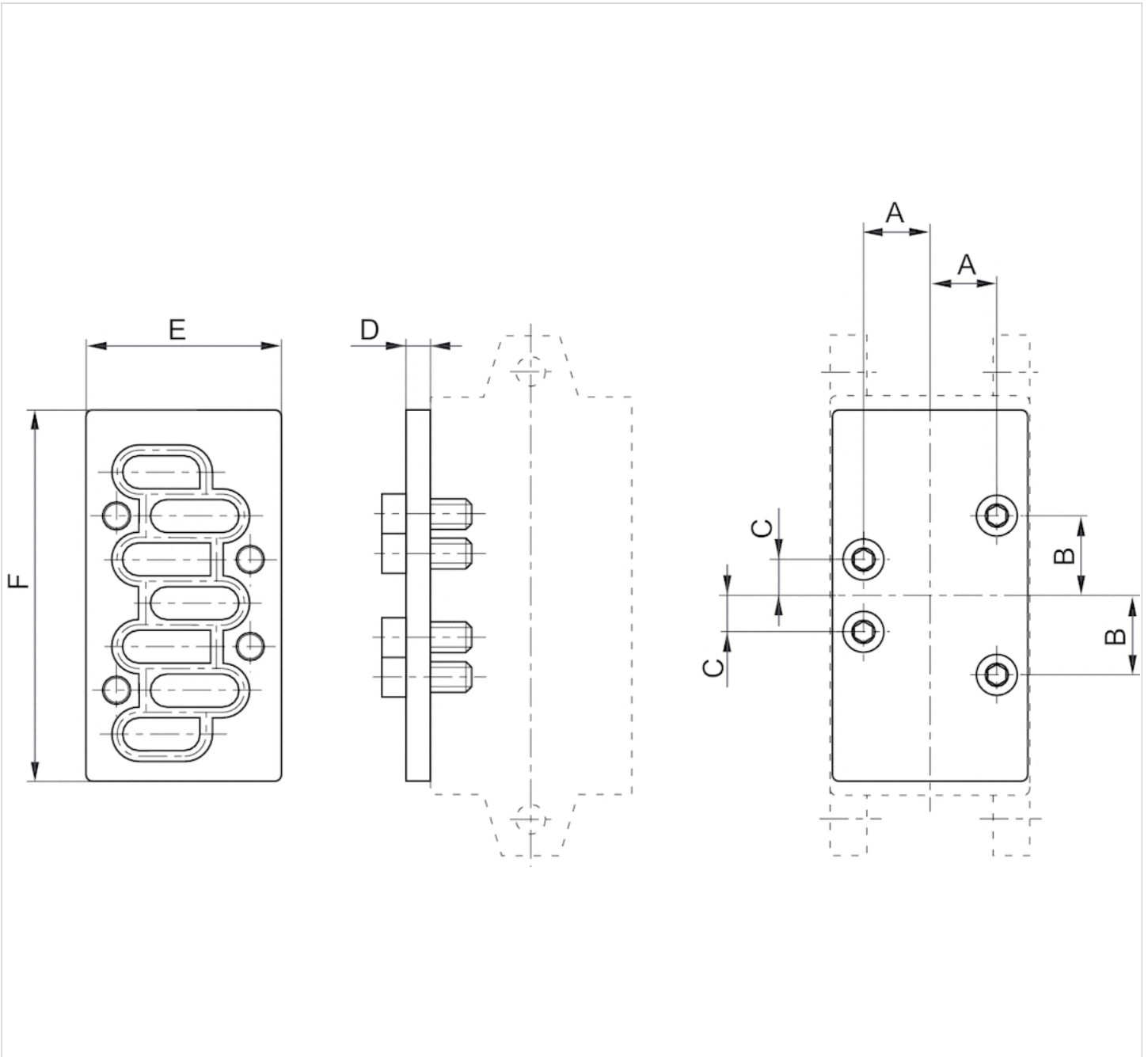

Dimensions

Part No.	Frame size	A	B	C	D	E	F
1825503176	ISO 2	19	24	12	15	54	100

Blanking plate

- standard ISO 5599-1

- Frame size ISO 2



Standards	ISO 5599-1
Working pressure min./max.	-1 ... 16 bar
Ambient temperature min./max.	-20 ... 70 °C
Medium temperature min./max.	-20 ... 70 °C
Medium	Compressed air
Number of valve positions max.	1
Weight	0,1 kg

Technical data

Part No.

5802870000

Scope of delivery incl. seal and mounting screws

Technical information

The min. control pressure must be adhered to, since otherwise faulty switching and valve failure may result!

The pressure dew point must be at least 15 °C under ambient and medium temperature and may not exceed 3 °C .

The oil content of compressed air must remain constant during the life cycle.

Use only the approved oils from AVENTICS. Further information can be found in the "Technical information" document (available in the MediaCentre).

Technical information

Material	
Housing	Die-cast aluminum, black painted
Base plate	Die-cast aluminum
Seal	Acrylonitrile butadiene rubber

Dimensions

Dimensions

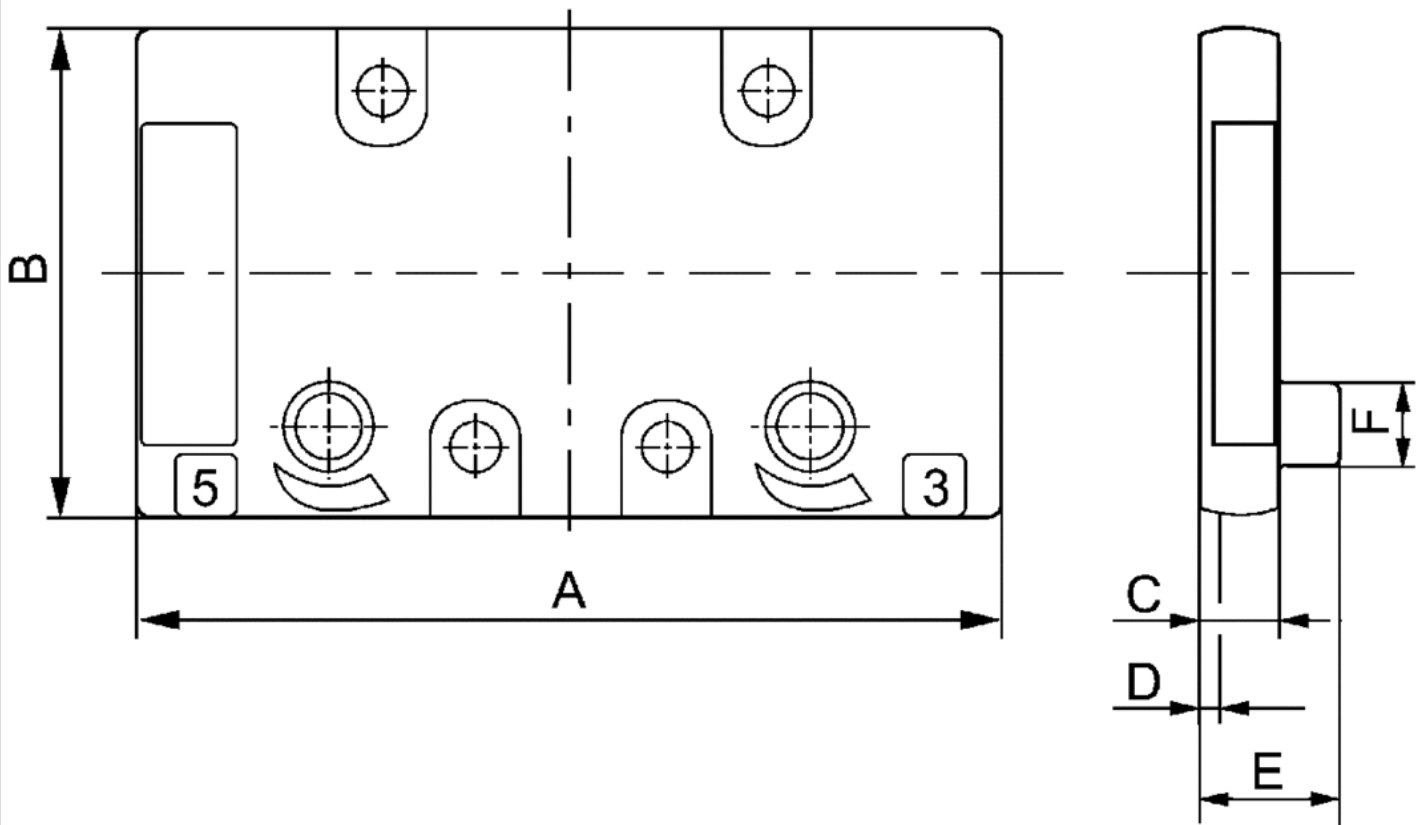

Dimensions

Part No.	A	B	C	D	E	F	Weight
5802870000	86.4	49.4	9	2	-	-	0,1 kg

Throttle plate

- standard ISO 5599-1
- Frame size ISO 2



Standards	ISO 5599-1
Working pressure min./max.	0 ... 16 bar
Ambient temperature min./max.	0 ... 80 °C
Medium temperature min./max.	0 ... 80 °C
Medium	Compressed air
Weight	0,444 kg

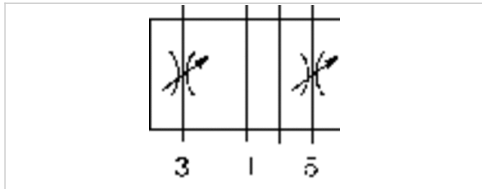

Technical data

Part No.
0821201024

Scope of delivery incl. seal and mounting screws

Technical information

The min. control pressure must be adhered to, since otherwise faulty switching and valve failure may result!
 The pressure dew point must be at least 15 °C under ambient and medium temperature and may not exceed 3 °C .
 The oil content of compressed air must remain constant during the life cycle.
 Use only the approved oils from AVENTICS. Further information can be found in the "Technical information" document (available in the MediaCentre).

Technical information

Material	
Base plate	Aluminum
Seal	Acrylonitrile butadiene rubber

Dimensions

Dimensions

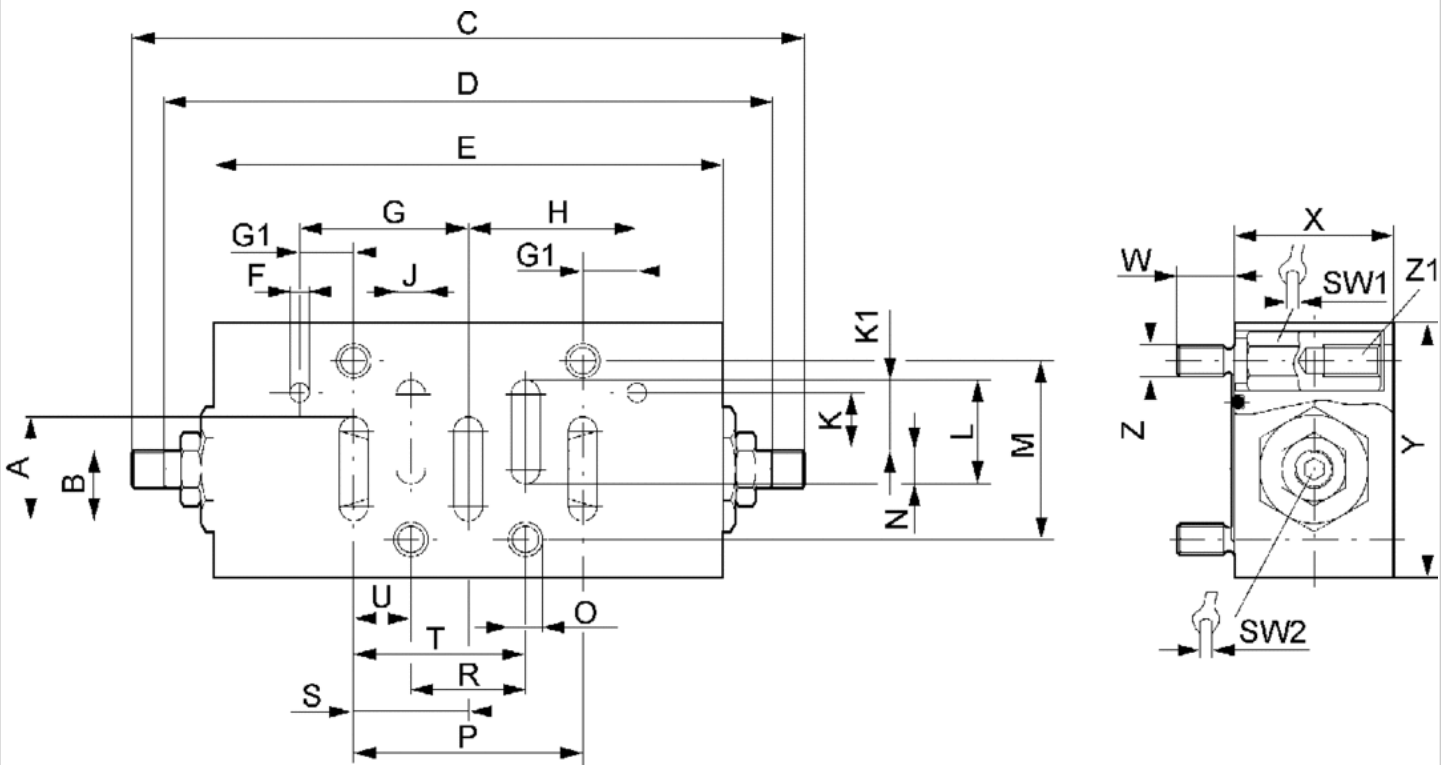

Dimensions

Part No.	A	B	C	D	E	F	G	G1	H	J	K	K1	L	M	N	O	P	R	S	SW1	SW2	T	U
0821201024	22	13,5	128.6	118.6	102	3	34	10	34	7	10	13.5	22	38	8.5	6.2	48	24	24	9	3	36	12

W	X	Y	Z	Weight	Z1
9	25	55	M6	0,444 kg	M6-10

Round plug connector, Series CON-RD

- Socket, M12x1, 4-pin, A-coded, straight, 180°
- UL (Underwriters Laboratories)
- unshielded



Connection type	Screws
Ambient temperature min./max.	-25 ... 90 °C
Operational voltage	48 V AC/DC
Protection class	IP67
Weight	0,029 kg
	The delivered product may vary from that in the illustration.

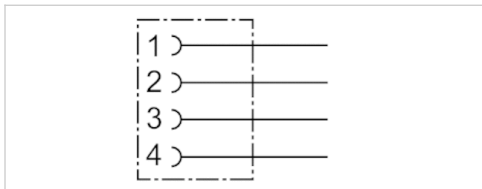

Technical data

Part No.	Max. current	suitable cable-Ø min./max
8941054324	4 A	4 mm

Technical information

The specified protection class is only valid in assembled and tested state.

Technical information

Material	
Housing	Polybutyleneterephthalate
Seals	Fluorocarbon caoutchouc

Dimensions

Dimensions

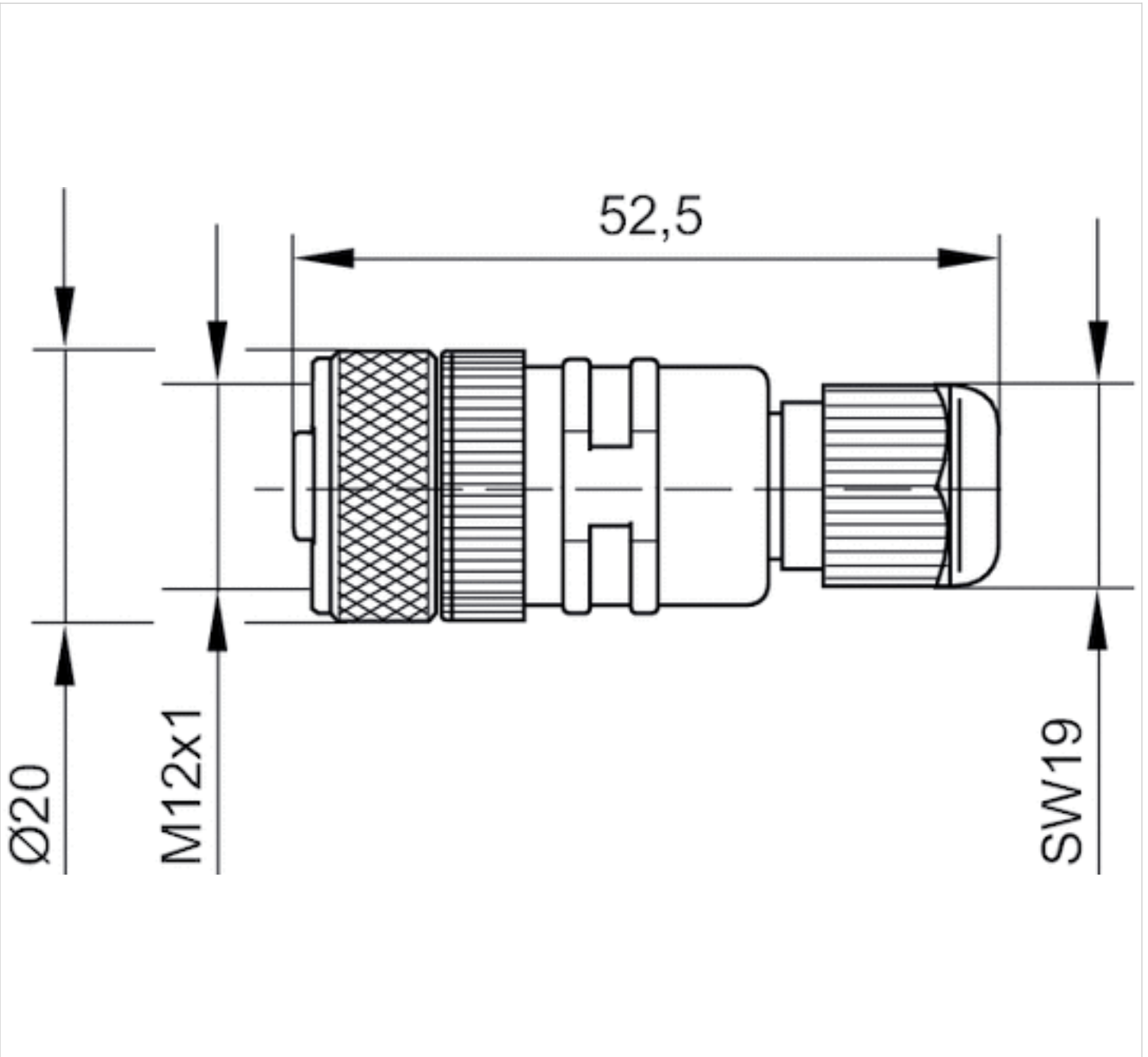

Pin assignments

Pin assignment, socket

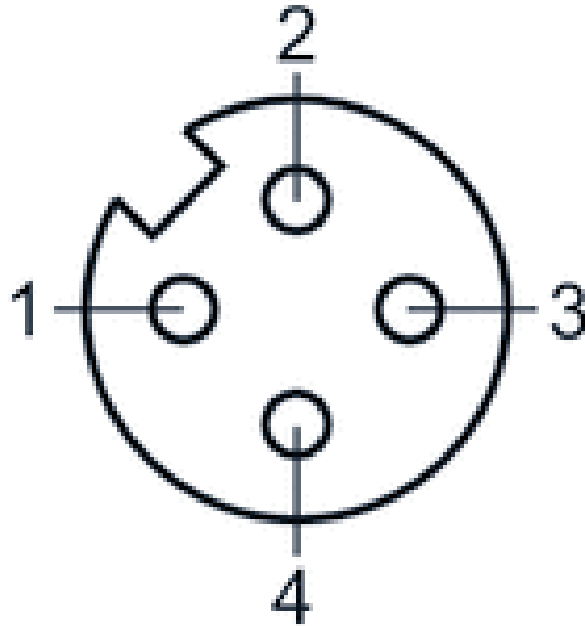

Round plug connector, Series CON-RD

- Socket, M12x1, 4-pin, A-coded, angled, 90°
- unshielded



Connection type	Screws
Ambient temperature min./max.	-40 ... 85 °C
Operational voltage	48 V AC/DC
Protection class	IP67
Weight	0,016 kg

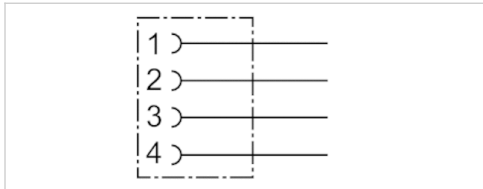

Technical data

Part No.	Max. current	suitable cable-Ø min./max
1834484178	4 A	4 mm

Technical information

The specified protection class is only valid in assembled and tested state.

Technical information

Material	
Housing	Polyamide

Dimensions

Dimensions

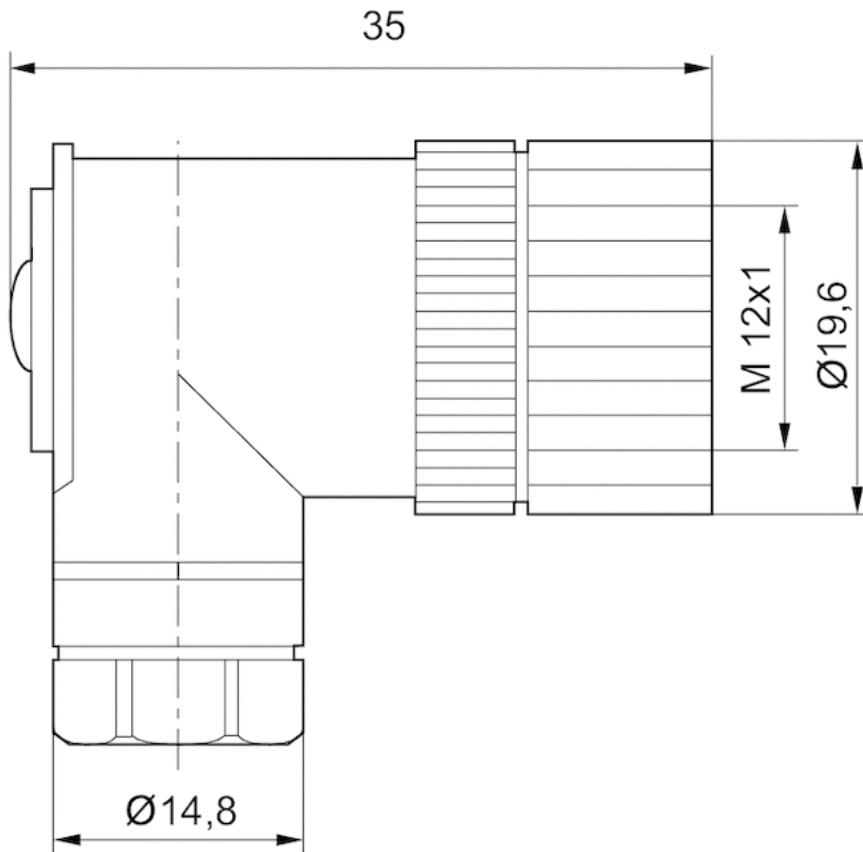

Pin assignments

Pin assignment, socket

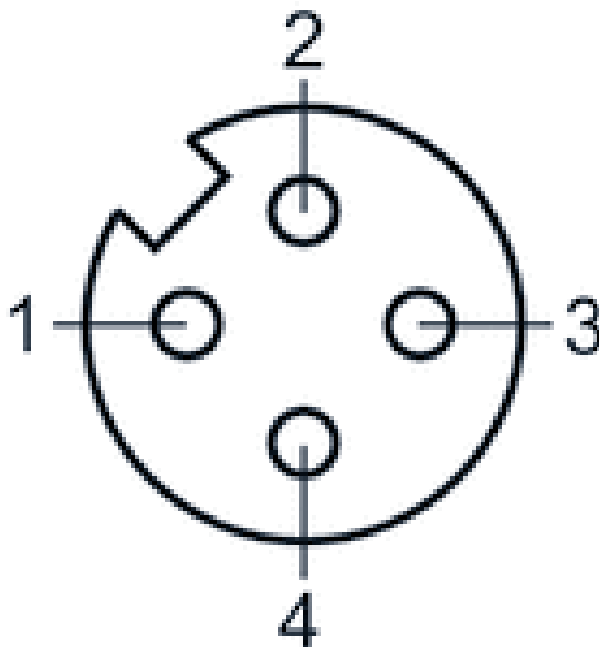

Round plug connector, Series CON-RD

- Socket, M12x1, 4-pin, A-coded, angled, 90°

- unshielded



Connection type	Screws
Ambient temperature min./max.	-25 ... 90 °C
Operational voltage	48 V AC/DC
Protection class	IP67
Weight	0,027 kg

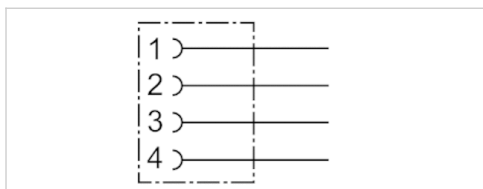

Technical data

Part No.	Max. current	suitable cable-Ø min./max
8941054424	4 A	4 mm

Technical information

The specified protection class is only valid in assembled and tested state.

Technical information

Material	
Housing	Polybutyleneterephthalate
Seals	Fluorocarbon caoutchouc

Dimensions

Dimensions

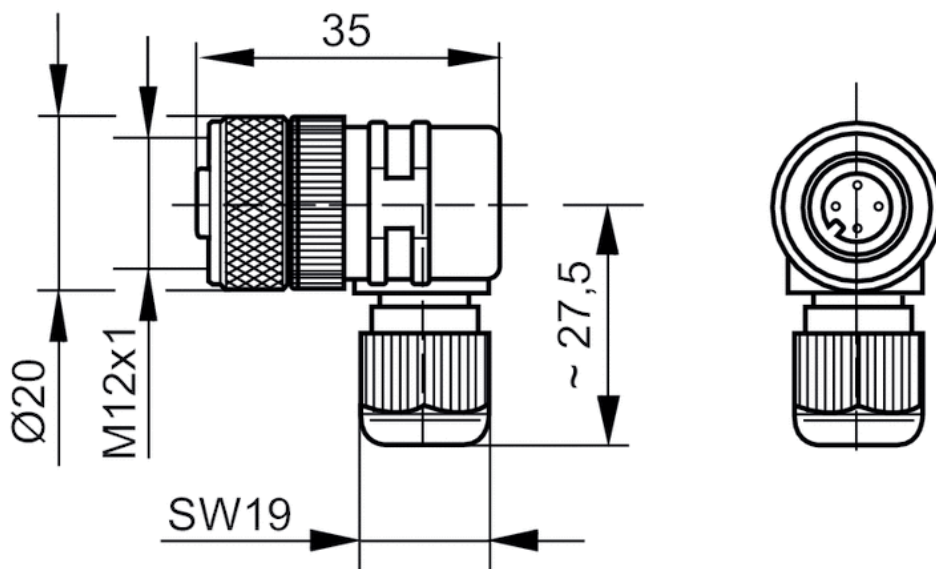

Pin assignments

Pin assignment, socket

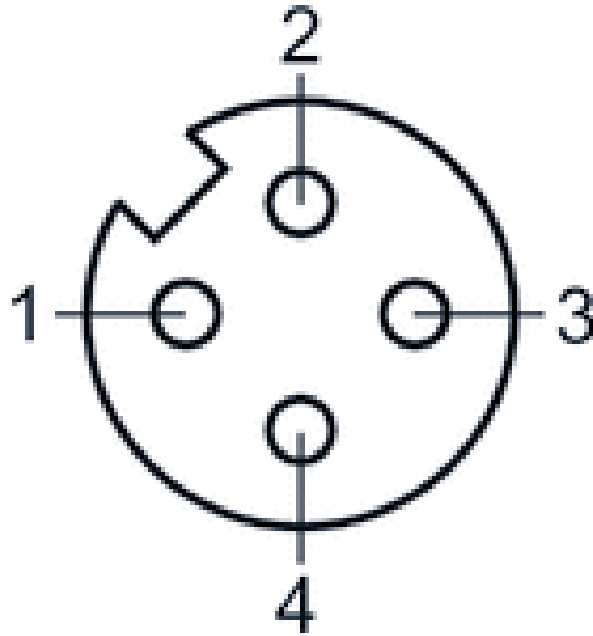

Round plug connector, Series CON-RD

- Socket M12x1 5-pin A-coded straight 180°
- open cable ends
- with cable
- unshielded



Ambient temperature min./max.	-25 ... 70 °C
Operational voltage	48 V AC/DC
Protection class	IP67
Wire cross-section	0,34 mm ²
Weight	See table below

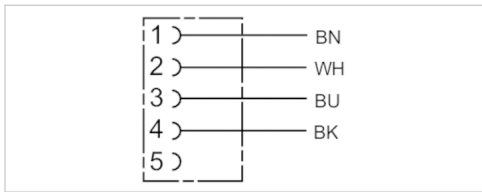

Technical data

Part No.	Max. current	Number of wires	Cable-Ø	Cable length	Weight
1834484256	4 A	4	5,2 mm	3 m	0,122 kg
1834484257	4 A	4	5,2 mm	5 m	0,194 kg
1834484258	4 A	4	5,2 mm	10 m	0,373 kg

Technical information

The specified protection class is only valid in assembled and tested state.

Technical information

Material	
Cable sheath	Polyurethane

Dimensions

Dimensions

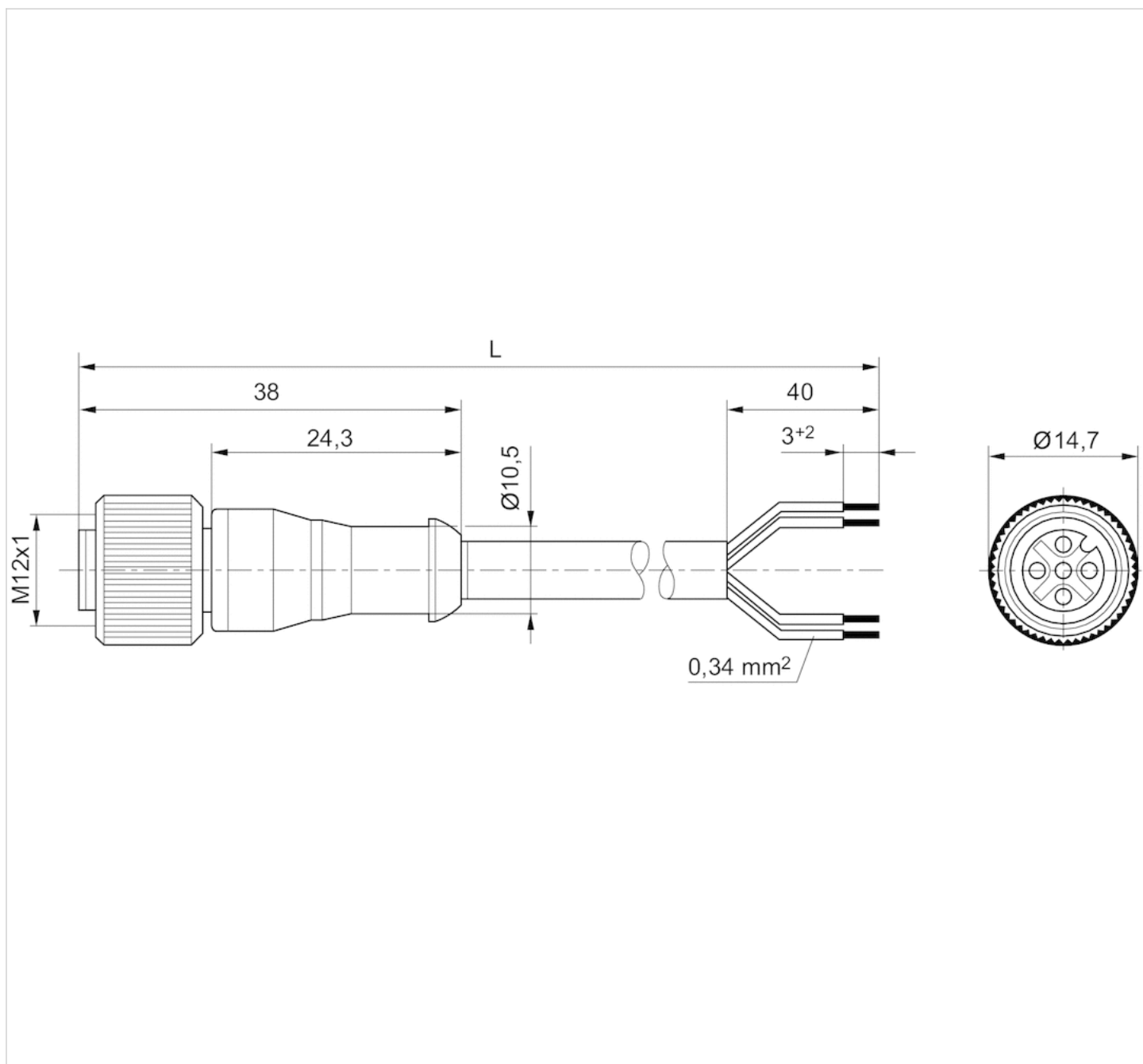

L = length

Pin assignments

Pin assignment, socket

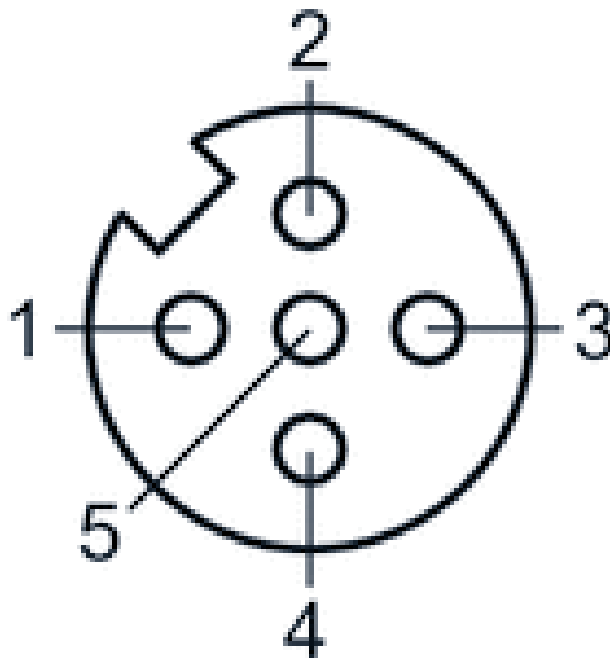

- (1) BN=brown
- (2) WH=white
- (3) BU=blue
- (4) BK=black
- (5) not assigned

Round plug connector, Series CON-RD

- Socket M12x1 5-pin A-coded angled 90°
- open cable ends
- for DeviceNet
- with cable
- unshielded



Ambient temperature min./max.	-40 ... 85 °C
Operational voltage	48 V AC/DC
Protection class	IP65
Wire cross-section	0,34 mm ²
Weight	See table below

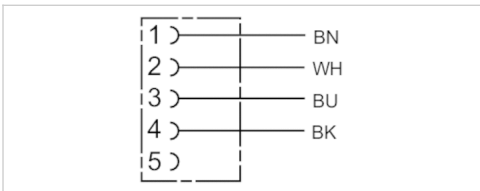

Technical data

Part No.	Max. current	Number of wires	Cable-Ø	Cable length	Weight
1834484259	4 A	4	5,2 mm	3 m	0,126 kg
1834484260	4 A	4	5,2 mm	5 m	0,195 kg
1834484261	4 A	4	5,2 mm	10 m	0,38 kg

Technical information

The specified protection class is only valid in assembled and tested state.

Technical information

Material	
Cable sheath	Polyurethane

Dimensions

Dimensions

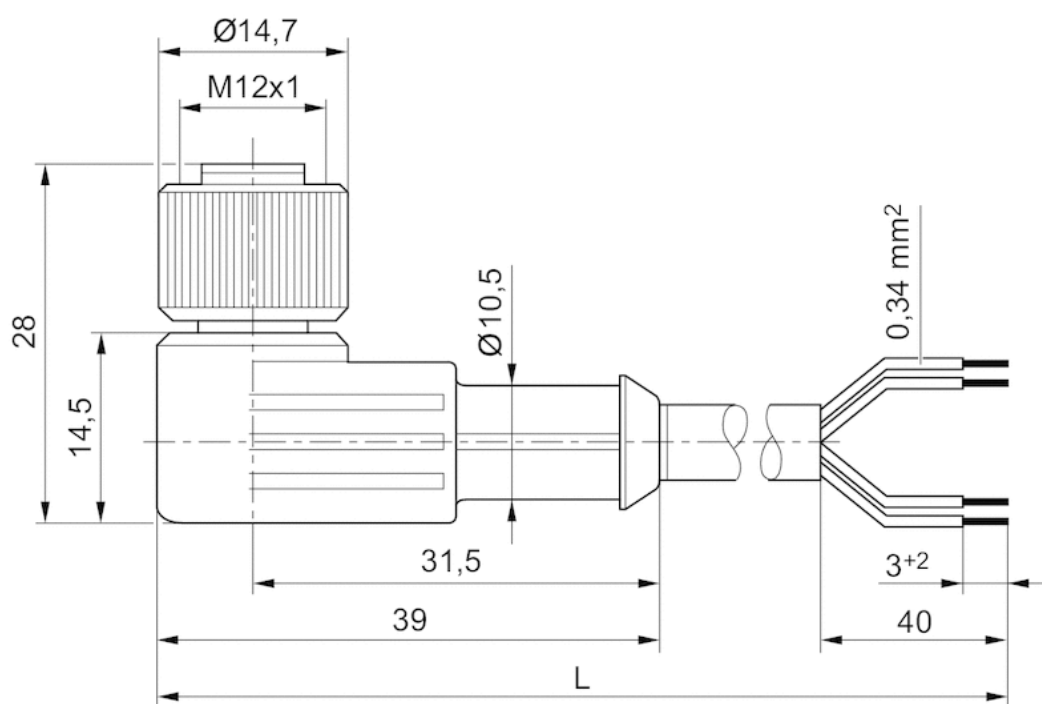

L = length

Pin assignments

Pin assignment, socket

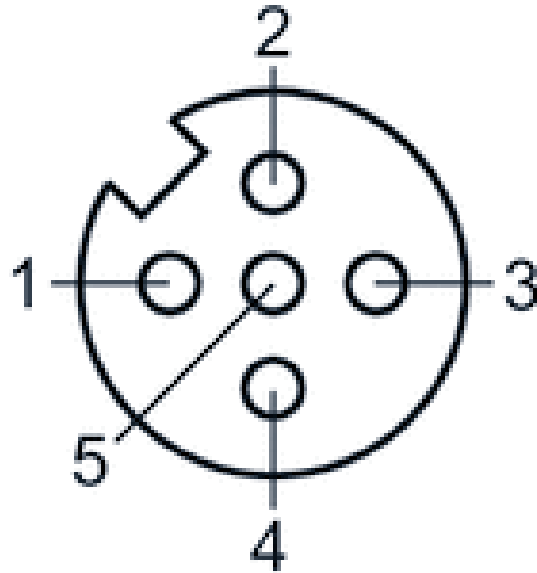

- (1) BN=brown
- (2) WH=white
- (3) BU=blue
- (4) BK=black
- (5) not assigned

Round plug connector, Series CON-RD

- Socket M12x1 4-pin A-coded straight 180°
- Plug M12x1 4-pin A-coded straight 180°
- EN 61076-2-101
- with cable
- unshielded



Ambient temperature min./max.	-40 ... 105 °C
Protection class	IP65 IP67 IP68 IP69
Wire cross-section	0,34 mm ²
Weight	See table below

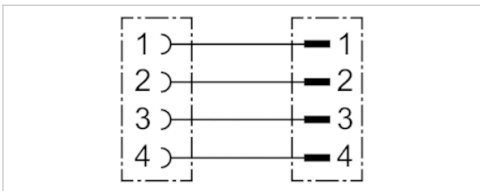

Technical data

Part No.	Max. current	Number of wires	Bending radius min.	Cable-Ø	Cable length	Delivery unit	Weight
R402003760	4 A	4	45 mm	4,5 mm	5 m	1 piece	0,258 kg
R402003761	4 A	4	45 mm	4,5 mm	10 m	1 piece	0,484 kg
R402003762	4 A	4	45 mm	4,5 mm	15 m	1 piece	0,721 kg

Technical information

The specified protection class is only valid in assembled and tested state.

Technical information

Material	
Housing	Polypropylene
Seals	Ethylene propylene diene monomer rubber
Cable sheath	Polyvinyl chloride

Dimensions

Dimensions

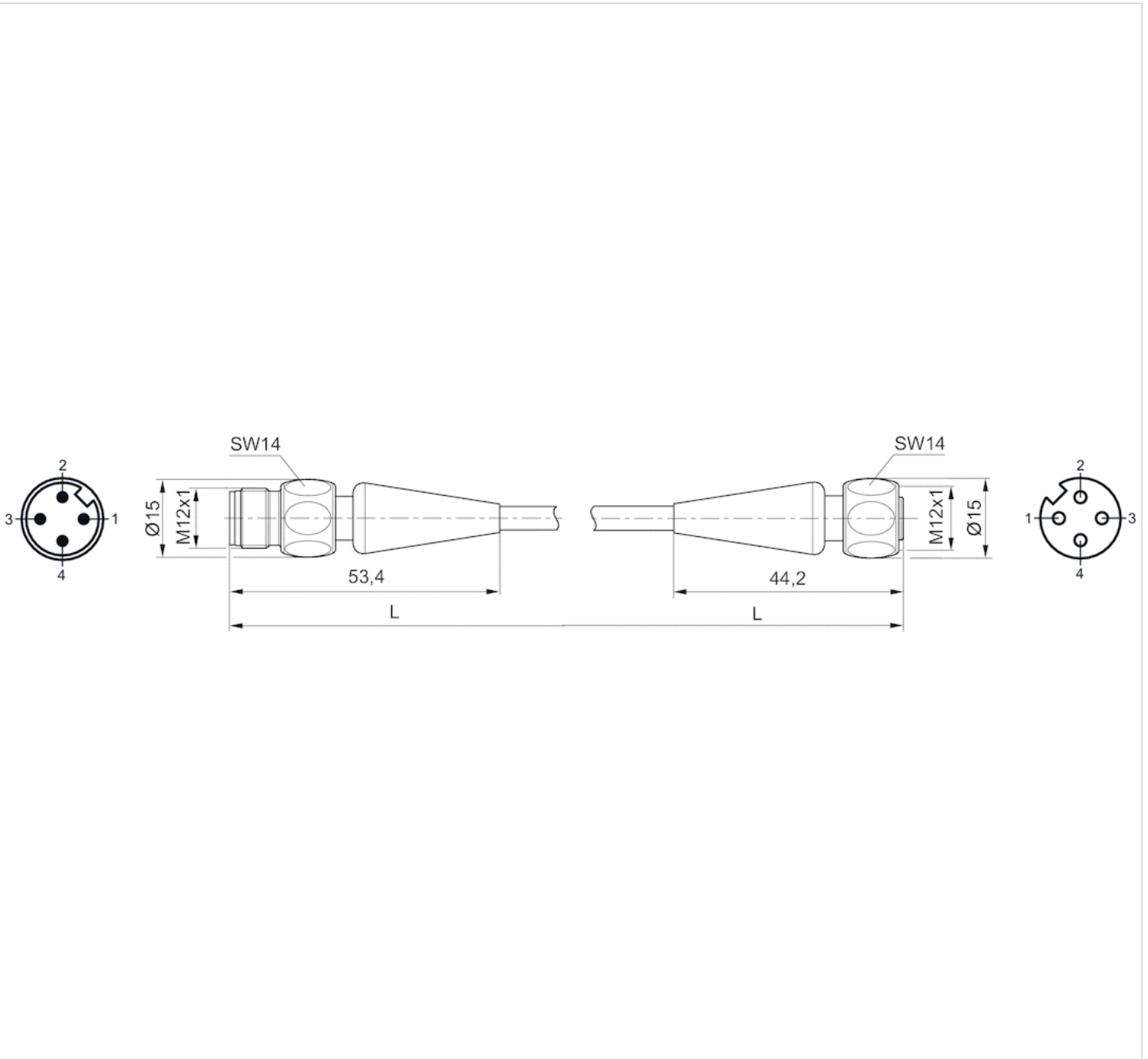

L = cable length

Pin assignments

Plug pin assignment

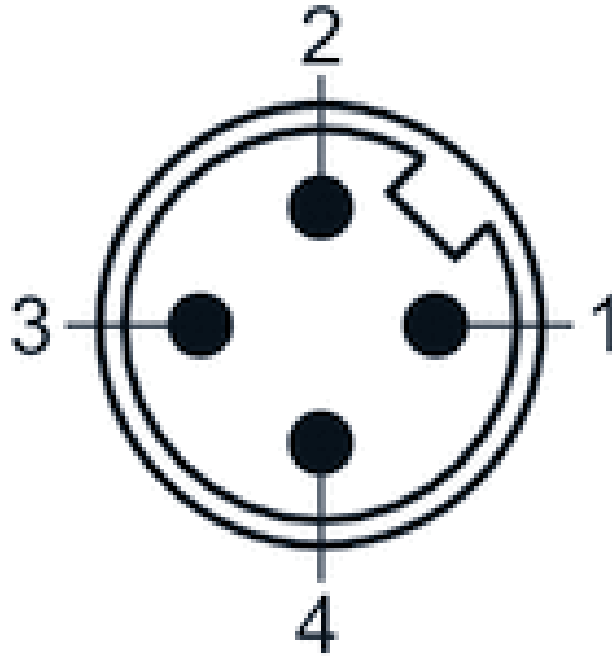

Pin assignment, socket

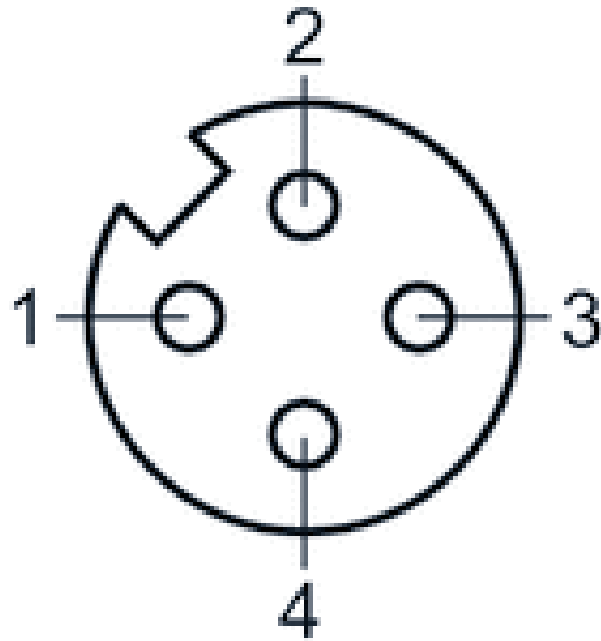

Round plug connector, Series CON-RD

- Socket M12x1 5-pin A-coded straight 180°
- Plug M12x1 5-pin A-coded angled 90°
- with cable
- suitable for dynamic laying
- unshielded



Ambient temperature min./max.	-25 ... 85 °C
Operational voltage	48 V AC/DC
Protection class	IP68
Wire cross-section	0,34 mm ²
Mounting screw tightening torque	0,8 Nm
Weight	See table below

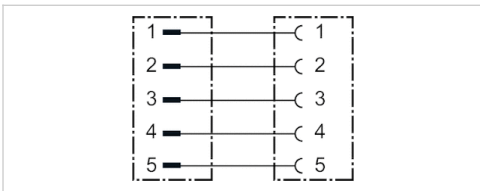

Technical data

Part No.	Max. current	Number of wires	Bending radius min.	Cable-Ø	Cable length	Weight
R412021694	4 A	5	50 mm	5 mm	2 m	0,114 kg
R412021695	4 A	5	50 mm	5 mm	5 m	0,217 kg

suitable for dynamic laying

Technical information

The specified protection class is only valid in assembled and tested state.

Technical information

Material	
Housing	Polyurethane
Cable sheath	Polyurethane

Dimensions

Dimensions

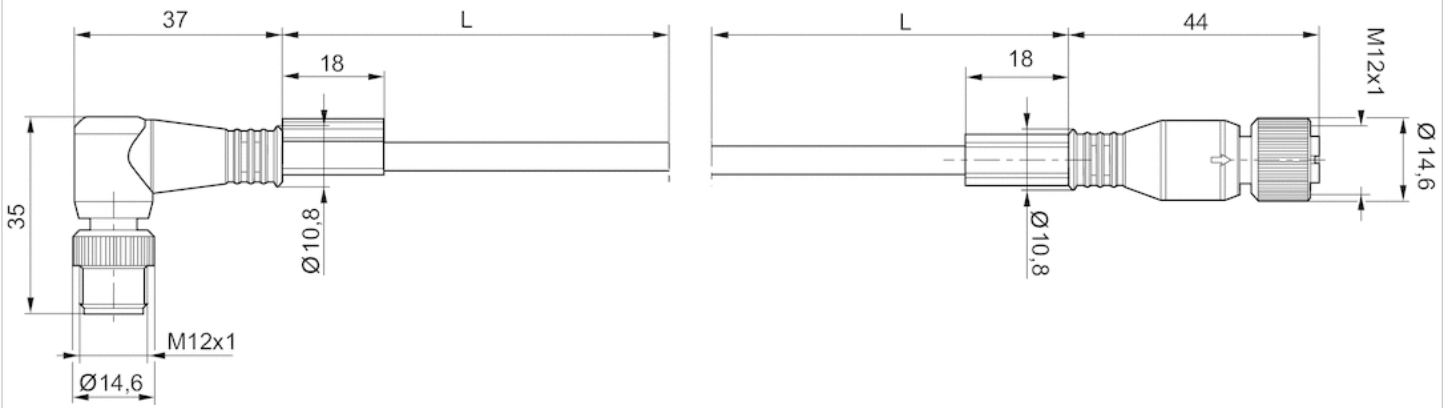

L = length

Pin assignments

Plug pin assignment

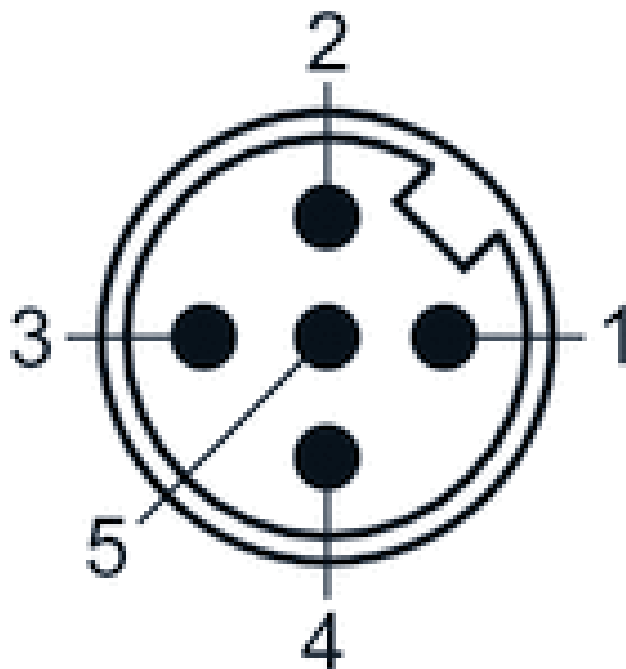

Pin assignment, socket

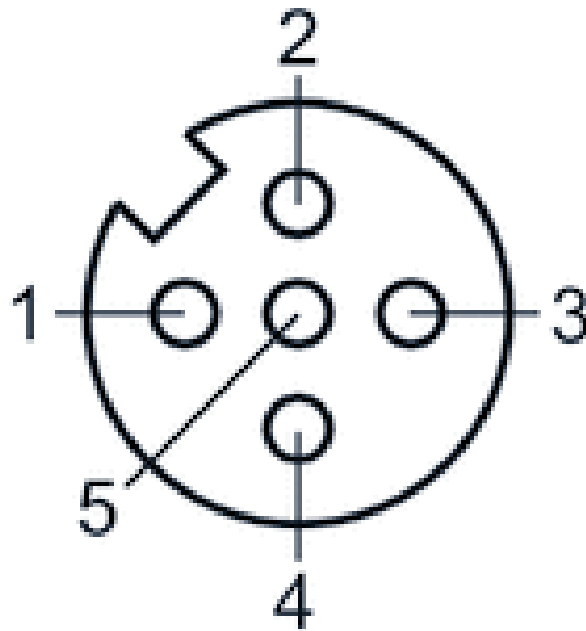

Round plug connector, Series CON-RD

- Socket, M12x1, 4-pin, A-coded, straight, 180°
- UL (Underwriters Laboratories)
- unshielded



Connection type	Screws
Ambient temperature min./max.	-40 ... 85 °C
Operational voltage	48 V AC/DC
Protection class	IP67
Weight	0,015 kg

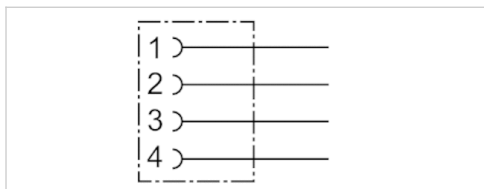

Technical data

Part No.	Max. current	suitable cable-Ø min./max
1834484177	4 A	4 / 6 mm

Technical information

Material	
Housing	Polyamide

Dimensions

Dimensions

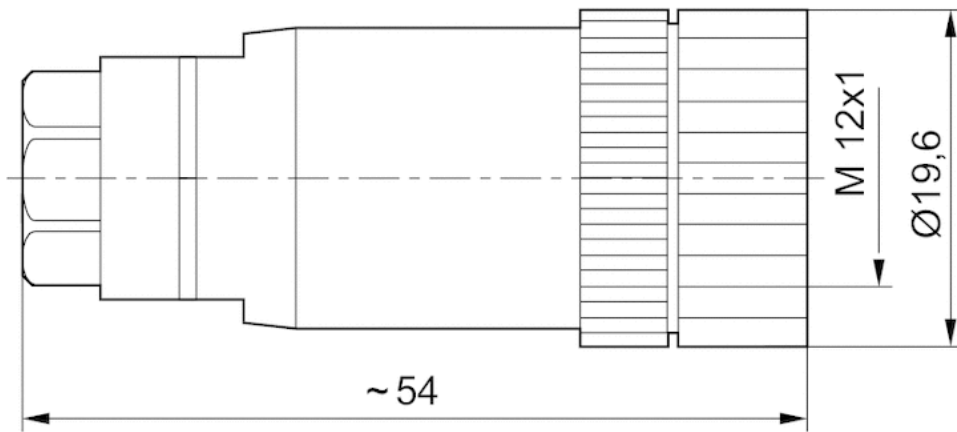

Pin assignments

Pin assignment, socket

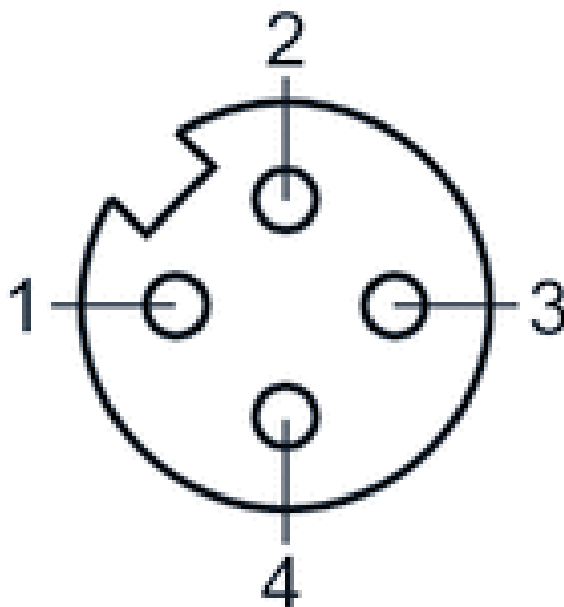

Valve plug connector, series CON-VP

- Socket, 2+E, angled, 90° Socket, 3+E, angled, 90°

- EN 175301-803

- unshielded

- with LED Yellow Red Green green/red



Connection type	Screws
Ambient temperature min./max.	-40 ... 90 °C
Operational voltage	See table below
Protection class	IP65
Mounting screw tightening torque	0,4 Nm
Weight	See table below

Technical data

Part No.	Electrical connection	Operational voltage	Max. current
1834484048	Socket 2+E angled 90°	-	10 A
1834484059	Socket 3+E angled 90°	-	10 A
1834484101	Socket 2+E angled 90°	24 V AC/DC	-
1834484102	Socket 2+E angled 90°	110 V AC	-
1834484103	Socket 2+E angled 90°	230 V AC	-
8941016112	Socket 2+E angled 90°	230 V AC	-
8941012462	Socket 3+E angled 90°	24 V DC	8 A

Part No.	Protective circuit	Contact assignment	LED status display	suitable cable-Ø min./max
1834484048	-	2+E	-	6 / 8 mm
1834484059	-	3+E	-	6 / 8 mm
1834484101	Z-diode	2+E	Yellow	6 / 8 mm
1834484102	Varistor	2+E	Red	6 / 8 mm
1834484103	Varistor	2+E	Red	6 / 8 mm
8941016112	Varistor	2+E	Green	6 / 10 mm
8941012462	-	3+E	green/red	4,5 / 11 mm

Part No.	Seal	Weight	
1834484048	caoutchouc/butadiene caoutchouc	0,03 kg	1)
1834484059	caoutchouc/butadiene caoutchouc	0,03 kg	1)
1834484101	Silicone caoutchouc	0,03 kg	2)
1834484102	caoutchouc/butadiene caoutchouc	0,03 kg	1)
1834484103	Silicone caoutchouc	0,025 kg	1)
8941016112	caoutchouc/butadiene caoutchouc	0,03 kg	1)
8941012462	caoutchouc/butadiene caoutchouc	0,03 kg	2)

- 1) Profile seal
- 2) Flat gasket

Technical information

The specified protection class is only valid in assembled and tested state.

Technical information

Material

Seals	caoutchouc/butadiene caoutchouc Silicone caoutchouc
-------	---

Dimensions

Dimensions

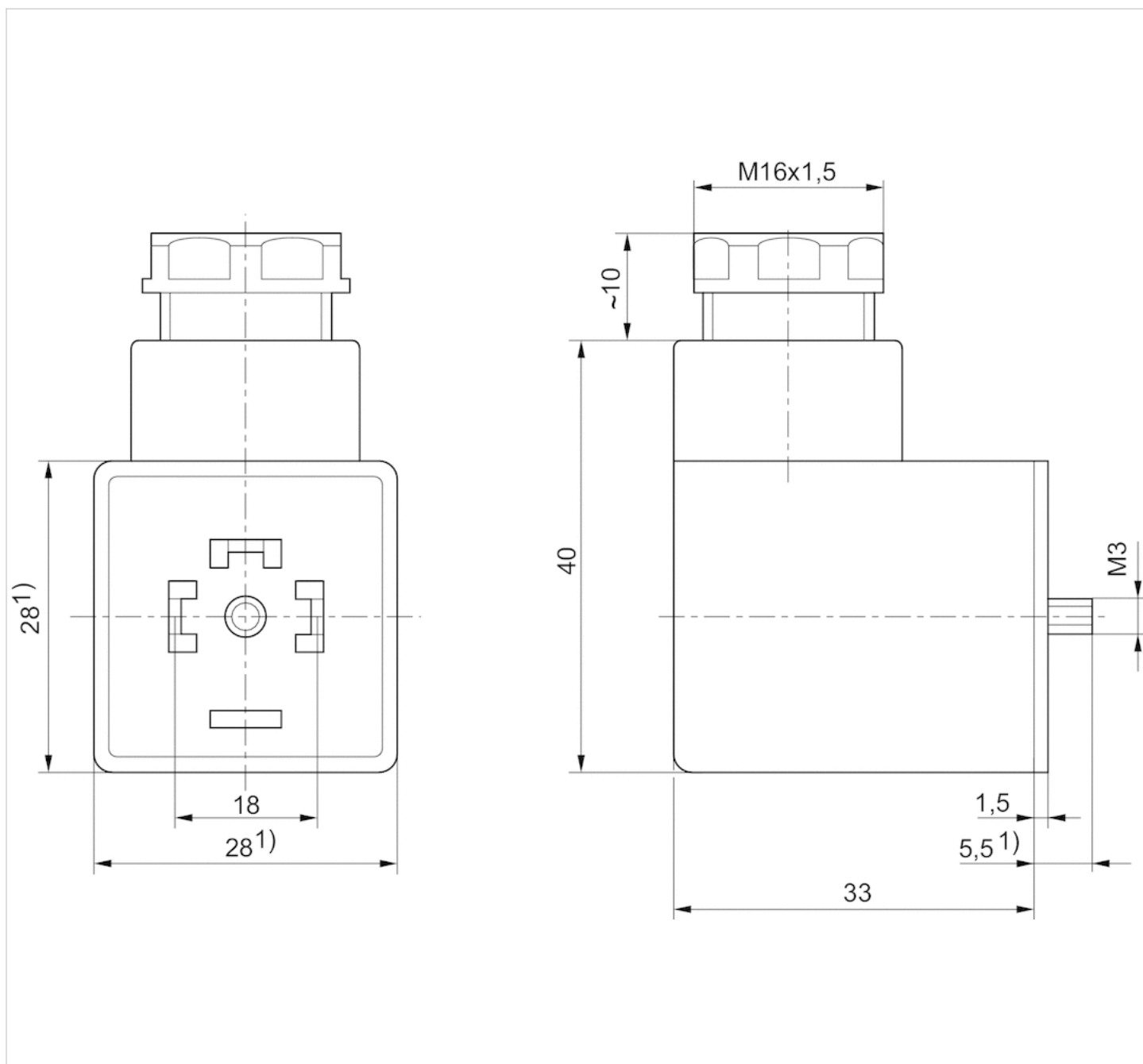

1) Max.





Valve plug connector, series CON-VP

- Socket form A 2+E angled 90°
- open cable ends 3-pin
- with cable
- unshielded



Ambient temperature min./max.	-20 ... 80 °C
Operational voltage	See table below
Protection class	IP67
Wire cross-section	0,75 mm ²
Mounting screw tightening torque	0,4 Nm
Weight	See table below

Technical data

Part No.		Operational voltage	Protective circuit	Contact assignment	LED status display
1834484160		230 V AC/DC	-	2+E	-
1834484162		24 V AC/DC	Z-diode	2+E	Yellow
1834484163		24 V AC/DC	Z-diode	2+E	Yellow
1834484164		230 V AC/DC	Varistor	2+E	Red
1834484165		230 V AC/DC	Varistor	2+E	Red

Part No.	Number of wires	Cable-Ø	Cable length	Weight	Fig.	
1834484160	3	5,9 mm	3 m	0,2 kg	Fig. 1	1)
1834484162	3	5,9 mm	3 m	0,2 kg	Fig. 2	-
1834484163	3	5,9 mm	5 m	0,31 kg	Fig. 2	-
1834484164	3	5,9 mm	3 m	0,2 kg	Fig. 2	-
1834484165	3	5,9 mm	5 m	0,31 kg	Fig. 2	-

1) Scope of delivery incl. flat gasket

Technical information

The specified protection class is only valid in assembled and tested state.

Technical information

Material	
Seals	caoutchouc/butadiene caoutchouc
Cable sheath	Polyvinyl chloride

Dimensions

Fig. 1

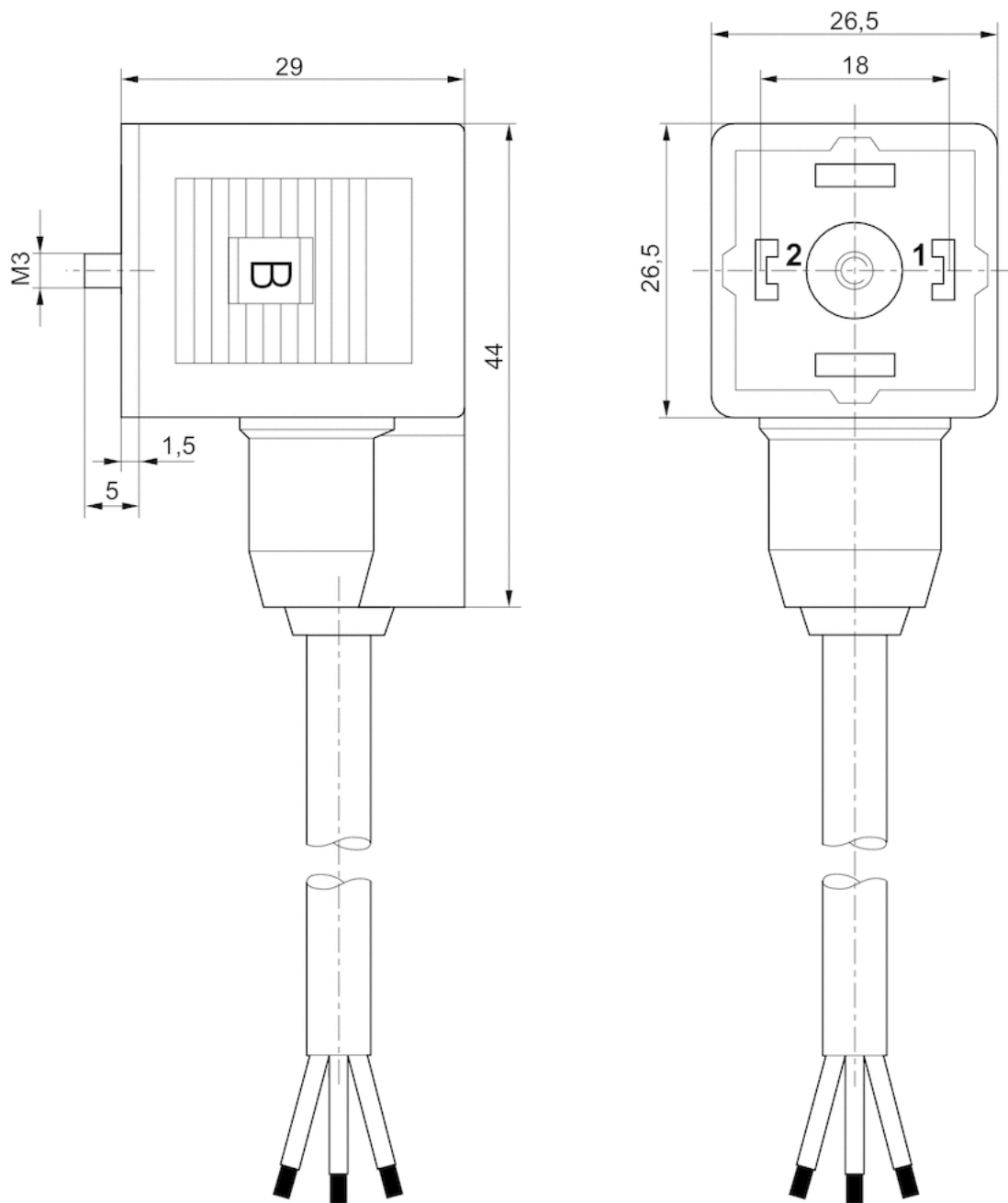
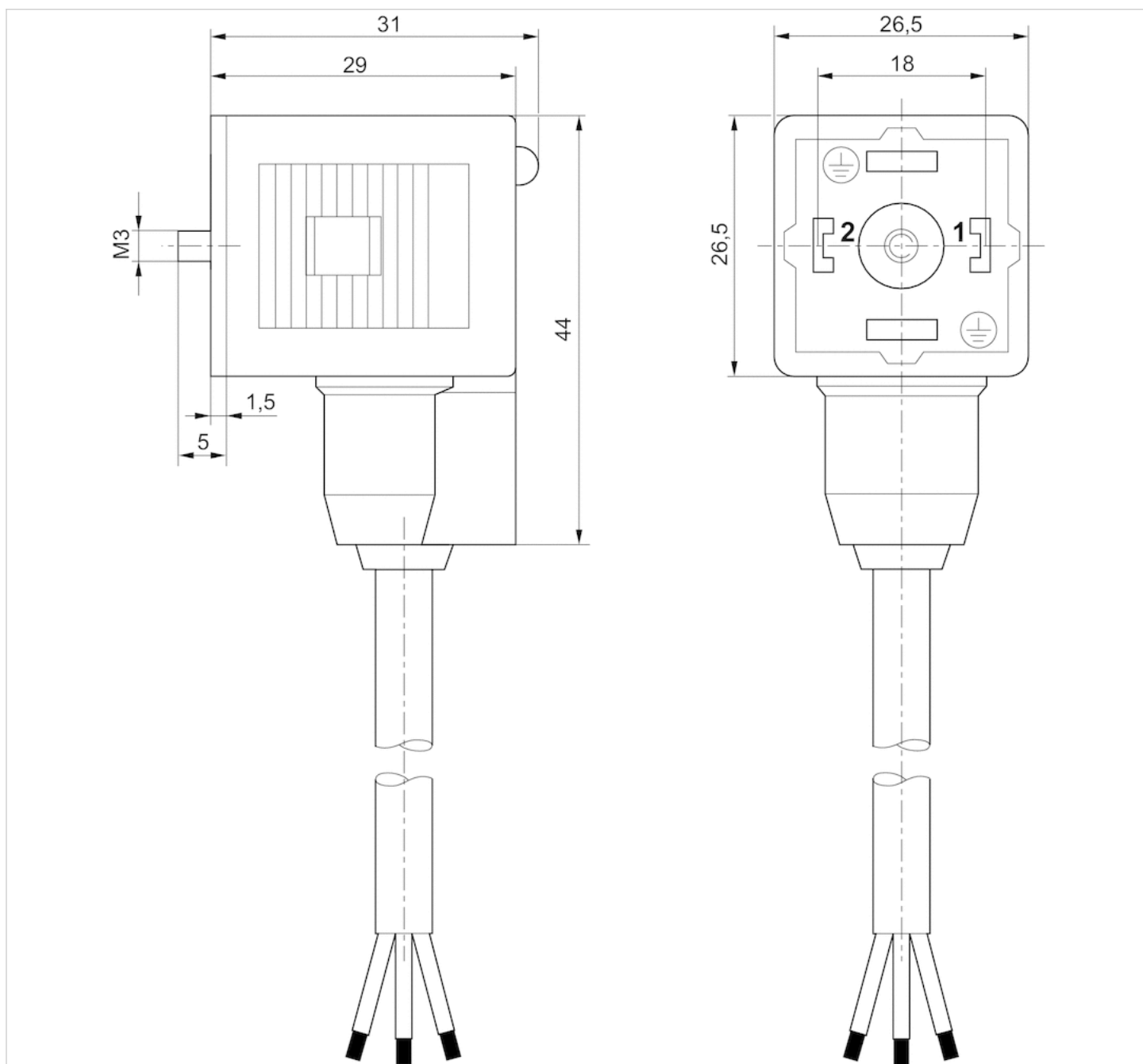

Fig. 2



Efficient pneumatic solutions, our program: cylinders and drives, valves and valve systems, air supply management



Visit us: [Emerson.com/Aventics](https://www.emerson.com/Aventics)

Your local contact: [Emerson.com/contactus](https://www.emerson.com/contactus)



Emerson.com



[Facebook.com/EmersonAutomationSolutions](https://www.facebook.com/EmersonAutomationSolutions)



[LinkedIn.com/company/Emerson-Automation-Solutions](https://www.linkedin.com/company/Emerson-Automation-Solutions)



[Twitter.com/EMR_Automation](https://twitter.com/EMR_Automation)

An example configuration is depicted on the title page. The delivered product may thus vary from that in the illustration. Subject to change. This Document, as well as the data, specifications and other information set forth in it, are the exclusive property of AVENTICS GmbH. It may not be reproduced or given to third parties without its consent. Only use the AVENTICS products shown in industrial applications. Read the product documentation completely and carefully before using the product. Observe the applicable regulations and laws of the respective country. When integrating the product into applications, note the system manufacturer's specifications for safe use of the product. The data specified only serve to describe the product. No statements concerning a certain condition or suitability for a certain application can be derived from our information. The information given does not release the user from the obligation of own judgement and verification. It must be remembered that the products are subject to a natural process of wear and aging.

The Emerson logo is a trademark and service mark of Emerson Electric Co. Brand logotype are registered trademarks of one of the Emerson family of companies. All other marks are the property of their respective owners. © 2021 Emerson Electric Co. All rights reserved.
2022-09



CONSIDER IT SOLVED™